

**Report for ANACOM**

**Bottom-up fixed cost model update  
Model documentation**

*5 July 2018*

## Confidentiality notice

---

- Confidentiality notice: This document and the information contained herein are strictly private and confidential, and are solely for the use of ANACOM
- Copyright © 2018. Analysys Mason Limited has produced the information contained herein for ANACOM. The ownership, use and disclosure of this information are subject to the Commercial Terms contained in the contract between Analysys Mason Limited and ANACOM

# Contents

---

## Introduction

Overview of the model

Market module

Network design module

Service costing module

Model results

Annexes

# ANACOM has commissioned Analysys Mason to build a fixed bottom-up LRIC model for wholesale voice termination in Portugal

- The Autoridade Nacional de Comunicações ('ANACOM') has commissioned Analysys Mason Limited ('Analysys Mason') to update a *pure* bottom-up long-run incremental cost ('pure BU-LRIC') model for wholesale voice call termination on individual public telephone networks provided at a fixed location in Portugal (Market 1)
- This document seeks to:
  - introduce the fixed cost model
  - provide a clear and comprehensive explanation of the algorithms, inputs and assumptions that have been implemented throughout the different parts of the model
- The model will be issued for public consultation, to invite industry stakeholders within the electronic communications sector in Portugal to provide input on the development of the model:
  - after the public consultation, the model and associated documentation will be updated in order to reflect the feedback received from the industry
- The remainder of this document is structured as follows:
  - overview of the model
  - market module
  - network design module
  - service costing module
  - model results
  - annexes

## Inputs to the public model have been consistently modified for confidentiality reasons

- The 2018 model has been populated and calibrated partly based on information provided by ANACOM and by the following fixed operators: MEO, NOWO, ONI, IP Telecom, Orange Business Services, Colt, NOS and Vodafone
  - inputs derived from those sources are confidential in its majority
  - the model often uses numbers based on this information
- To protect the confidential information from the market, all inputs from the public model have been modified
  - inputs have been modified by a random percentage of between -15% and +15%
  - for instance, if a variable has a value of 1 in the confidential model, it could have any value between 0.85 and 1.15 in the public model
- This will only slightly alter the final result of the model (Pure LRIC and LRAIC+) and will still allow interested parties to understand the inner workings of the model

The same inputs anonymisation methodology in this model was also followed in the public versions of the 2014 fixed LRIC model and for the 2017 LRIC model developed to calculate mobile termination costs (MTR) in Portugal

---

Introduction

**Overview of the model**

Market module

Network design module

Service costing module

Model results

Annexes

## We retained the modelling principles of the 2014 model [1/2]

- The modelling approach taken for the BU-LRIC model has been defined based on:
  - the EC Recommendation of 2009 <sup>(1)</sup> regarding the application of a pure LRIC approach
  - the approach adopted in other fixed costs models published by other European regulators
  - answers from industry players to a Concept Paper in the 2014-2015 process presenting the main modelling options
- **Methodology** – In line with the EC 2009 Recommendation and as requested by ANACOM, we have used a bottom-up architecture to construct a pure LRIC model:
  - this approach increases the transparency of the underlying calculations
  - it also facilitates the specification of a hypothetical operator by providing a consistent model framework
- **Network footprint** – The geographical scope of the model is national, comparable to that offered by the fixed operators in Portugal:
  - the hypothetical operator begins to roll out its network in 2009, achieving the target network coverage within the first three years from launch
- **Scale of the operator** – The modelled operator has a market share of  $1/n$  in the long term, where  $n$  is equal to the number of fixed operators with a significant scale per geotype:
  - the operator launches service in 2010 and needs a period of four years to reach full scale
- **Access network** – The access layer is based on copper and fibre:
  - migration from copper to fibre considers the next-generation access (NGA) Gigabit passive optical network (GPON) roll-out and roll-out plans of the Portuguese fixed operators
  - the demarcation point between traffic- and non-traffic-related costs is located at the first point of traffic concentration (i.e. at the digital subscriber line access multiplexer (DSLAM)) for copper subscribers and at the optical line termination (OLT) point for fibre subscribers)
- **Core network** – We have modelled a next-generation network (NGN) bandwidth allocation protocol (BAP) IP core architecture:
  - this is in line with the European Commission (EC) Recommendation of 2009, which states that “*the core part could be assumed to be NGN-based*”<sup>(1)</sup>

<sup>(1)</sup> COMMISSION RECOMMENDATION of 7 May 2009 on the Regulatory Treatment of Fixed and Mobile Termination Rates in the EU(2009/396/CE). Available at <http://eur-lex.europa.eu/LexUriServ/LexUriServ.do?uri=OJ:L:2009:124:0067:0074:EN:PDF>

## We retained the modelling principles of the 2014 model [2/2]

- **Transmission** – The model allows to select between IP/MPLS over Ethernet and IP/MPLS over SDH:
- **Services** – The model includes all major services provided by fixed operators in Portugal:
  - voice services (retail and wholesale)
  - data services (dial-up Internet, broadband and leased lines)
  - multimedia services (Internet protocol television (IPTV), video-on-demand (VoD) and over-the-top (OTT))
  - economies of scope have been shared across voice, data and multimedia services in the LRAIC+ model
- **Increment** – As recommended by the EC, a pure LRIC approach is applied in the model:
  - LRAIC+ costs have also been modelled for information purposes
- **Wholesale network costs** – The model covers network activities plus common business overheads:
  - retail costs (such as dealer payments, promotions, customer care, sales and marketing) have not been modelled
  - the LRAIC+ results include a share of relevant business overheads
  - the pure LRIC results exclude all common cost components
- **Depreciation** – We have used an economic depreciation calculation expressed in real 2017 EUR:
  - this is the same functional form of economic depreciation that Analysys Mason has applied in similar regulatory cost models in the Netherlands, Denmark, Norway, France, Sweden and Belgium, and was satisfactorily tested by Ofcom during its economic depreciation considerations
  - moreover, this was the methodology used in Portugal itself for the 2014 fixed model and in the mobile cost model previously developed by Analysys Mason for ANACOM
- **WACC** – The model uses MEO's 2017 pre-tax real weighted average cost of capital (WACC), 7.56%, derived by de-inflating the one in nominal terms calculated by ANACOM and equal to 9.0651%. <sup>(1)</sup>
- **Years of calculation** – The model calculates costs over the lifetime of the business, including those associated with ongoing equipment replacements:
  - discounted over 45 years
  - the terminal value beyond 45 years is assumed to be negligible

<sup>(1)</sup> Determinação da taxa de custo de capital da MEO – Serviços de Comunicações e Multimédia, S.A. Available at: [https://www.anacom.pt/streaming/RelatorioWACC16maio2017..pdf?contentId=1413506&field=ATTACHED\\_FILE](https://www.anacom.pt/streaming/RelatorioWACC16maio2017..pdf?contentId=1413506&field=ATTACHED_FILE)



## The model follows a modular approach [1/2]

Structure of the fixed BU-LRIC model

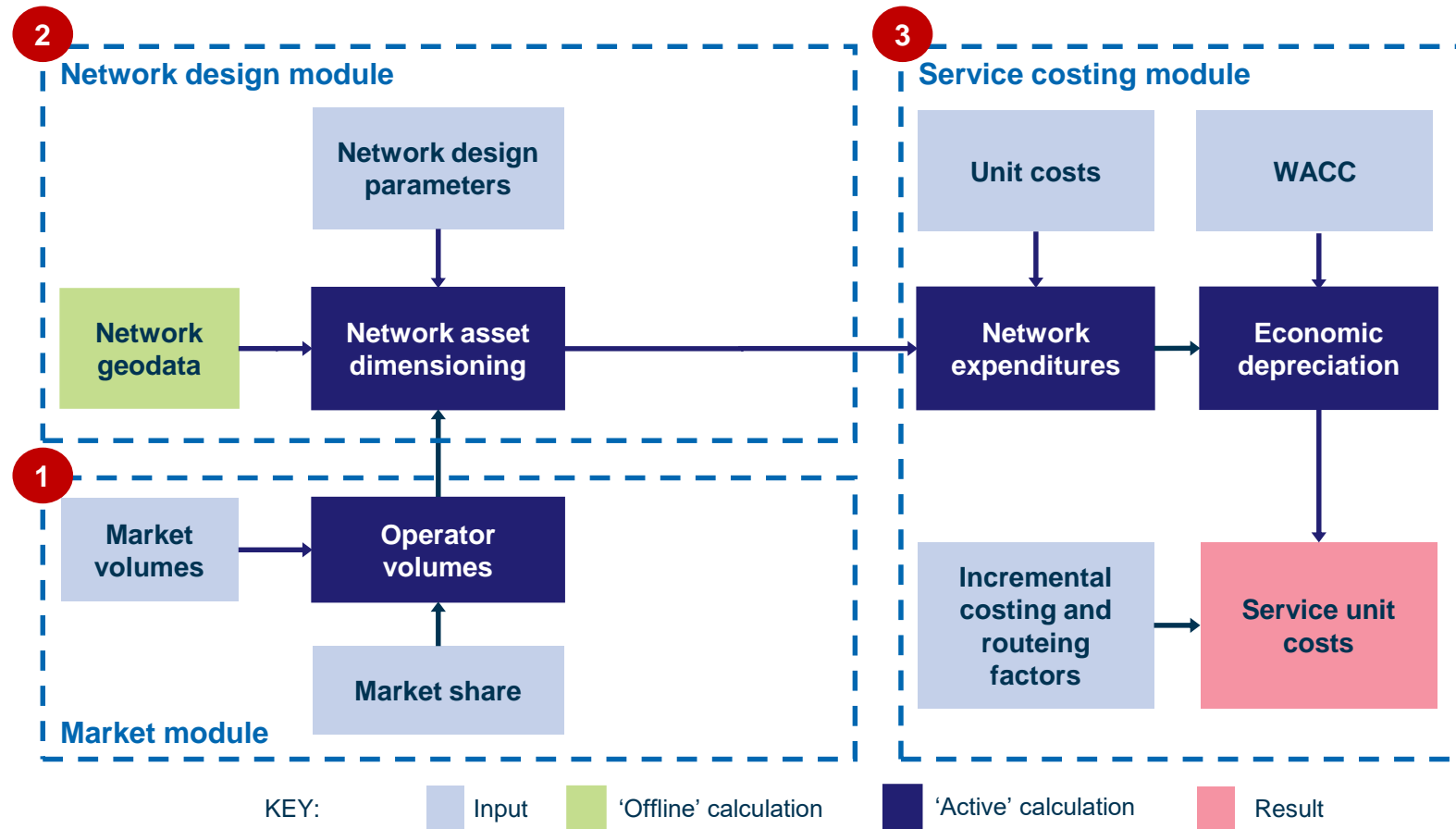

## The model follows a modular approach [2/2]

### 1 Market module:

- **Market volumes** – Historical data and projections of market subscribers and traffic per service and geotype
- **Market share** – Market share of the modelled operator
- **Operator volumes** – Market subscribers and traffic for the modelled operator

### 2 Network design module:

- **Network geodata** – Geo/route analysis resulting from offline calculations
- **Network design parameters** – Busy-hour factors, coverage parameters, switch capacities, network topology, etc.
- **Network asset dimensioning** – Calculation of the number of network assets to be purchased over the modelled period

### 3 Service costing module:

- **Unit costs** – Modern equivalent asset (MEA) input prices for network elements, indirect costs, business overheads and cost trends over time
- **Network expenditures** – Calculation of capital and operational expenditure (opex and capex) over time
- **WACC** – Discount rate for the modelled operator
- **Economic depreciation** – Annualisation of expenditure according to defined economic principles
- **Incremental costing and routing factors** – Average resource consumption inputs
- **Service unit costs** – Calculation of pure LRIC and/or LRAIC+ unit costs

## Structure of the market module

- The market module forecasts the subscriber and traffic demand. This module is included in the file *1. Market.xlsx*
- The sheet *Control* in the file *1. Market.xlsx* allows the user to set the values for each of the sensitivities implemented in the model. The parameters that can be selected are as follows:
  - the **‘WACC’** sensitivity changes the discount rate at which the economic depreciation is calculated
  - the **‘Market share’** sensitivity (both at launch and at the target year) allows the user to modify the market share of the modelled operator per geotype
  - the **‘Share of IP interconnected traffic’** sensitivity (both at launch and at the target year) modifies the percentage of voice traffic interconnected with IP (instead of TDM) in the launch and in the target year
  - the **‘Voice bitrate’** sensitivity allows to use a different codec for voice conversion and transmission
  - the **‘Demand’** sensitivity modifies the compound average growth rate (CAGR) of our traffic forecasts between 2017\* and 2025
  - the **‘Transmission technology’** sensitivity allows to change the transmission technology by network level (e.g. DWDM, CWDM, NG-SDH)
  - the **‘Share of SDH traffic’** sensitivity allows to modify the proportion of transmission traffic carried using NG-SDH in the access layer both at the launch and at the target year
  - the **‘OTT traffic’** sensitivity excludes OTT traffic for both network dimensioning and service costing
  - in the **‘Mark-up for IT costs?’** sensitivity, unit costs are increased by 6% to take into account additional IT overhead costs
  - the **‘Asset lifetimes’** sensitivity modifies the asset lifetimes
  - in the **‘Unit capex’** sensitivity the unit capex inputs are changed
  - the **‘Cost trends’** sensitivity modifies the price trend for the different network items
  - the **‘Call server’** sensitivity allows to modify the approach for the dimensioning and costing of the main VoIP traffic routing equipment
  - in the **‘Interconnection team’** sensitivity, the number of full-time equivalent (FTE) employees is increased from 9 to 13 (i.e. no change between the with and without termination cases)

## Structure of the network design module

---

- The network design module calculates the loading of each network element based on the traffic demand forecasts. This module is included in the file *2. Network.xlsx*
- The most important inputs for the network design module are:
  - operator traffic volumes, produced by the market module
  - geo/route analysis, resulting from an offline calculation
  - a range of network parameters specified in the sheet *Network design inputs* within the file *2. Network.xlsx*
  - lifetime parameters specified in the sheet *Asset\_inputs* within the file *2. Network.xlsx*
- The sheet *Full\_network* collates the number of network elements required of each type (e.g. number of DSLAMs, core routers) per annum
- A full description of the module sheets and inputs is provided in the annex to this document

## Structure of the service costing module

---

- The service costing module collects the results from the market and network design modules, and calculates the service costing results for the increment used. This module is included in the files 2. *Network.xlsx* and 3. *Service costing.xlsx*
- The capex unit costs are based on operator data where available, or Analysys Mason's estimates otherwise. These unit costs include:
  - capex direct costs, covering the hardware, and/or software, purchase price
  - spares costs and a capitalised installation and commissioning mark-up
- Annual opex consists of:
  - direct opex, such as rent or leases
  - operations and maintenance expenditure, expressed as a percentage of total costs
- When the macro runs, costs per minute and per Mbit/s are calculated for each of the services included in the model:
  - the sheet *Results\_fixed* summarises the pure LRIC and LRAIC+ results of the model; a '*check zero*' section has been included in this sheet to ensure consistency between the different parts of the model
- A full description of the module sheets and inputs is provided in the annex to this document

Introduction

Overview of the model

**Market module**

Network design module

Service costing module

Model results

Annexes



**Overview of the module**

Voice services

Data services

Multimedia services

Geotyping approach

## The market module uses a combination of inputs from ANACOM, reputable third-party data sources and Analysys Mason estimates

### Main inputs used in the market module

Input	Historical data source	Forecast data source
Population	Portuguese MTR 2017 model	Portuguese MTR 2017 model
Households	Portuguese MTR 2017 model	Analysys Mason Research, Euromonitor International
Fixed voice connections	ANACOM	Analysys Mason Research, historical data
Mobile voice connections	Portuguese MTR 2017 model	Portuguese MTR 2017 model
Fixed broadband connections	ANACOM	Analysys Mason Research, historical data
Leased lines	ANACOM	Historical data
Pay-TV connections	ANACOM	Analysys Mason Research, historical data
VoD and OTT subscribers	ANACOM, Analysys Mason estimates	Analysys Mason Research
Voice traffic per fixed subscriber	ANACOM	Historical data
Voice traffic per mobile subscriber	ANACOM	ANACOM mobile cost model, historical data
Data traffic per broadband subscriber	ANACOM	Analysys Mason Research, historical data
International incoming traffic	ANACOM	Historical data
Wholesale outgoing traffic	ANACOM	Historical data
Wholesale transit traffic	ANACOM	Historical data

## The market module forecasts traffic demand for the full set of services provided over fixed networks in Portugal

### Services provided over fixed networks in Portugal

Service	Service		
Local on-net calls (retail)	Local outgoing calls to non-geographic numbers (wholesale)		
National on-net calls (retail)	Single-tandem outgoing calls to non-geographic numbers (wholesale)		
Non-geographical on-net calls (retail)	Double-tandem outgoing calls to non-geographic numbers (wholesale)		
Outgoing calls to mobile (retail)	Local transit calls (wholesale)	1	Voice services
Outgoing calls to other fixed operators (retail)	Single-transit calls (wholesale)		
Outgoing calls to international numbers (retail)	Double-transit calls (wholesale)		
Incoming calls to non-geographic numbers	National to international or international to national transit calls (wholesale)		
Other outgoing calls (retail)	International transit calls (wholesale)		
Local incoming calls (wholesale)	Other transit calls (wholesale)		
Simple tandem incoming calls (wholesale)	Dial-up Internet	2	Data services
Double tandem incoming calls (wholesale)	Broadband (direct access)		
International incoming calls (wholesale)	Bitstream (indirect access)		
Other incoming calls (wholesale)	Leased lines		
Local outgoing calls (wholesale)	TV (IPTV)	3	TV and OTT services
Simple tandem outgoing calls (wholesale)	TV (VoD)		
Double tandem outgoing calls (wholesale)	OTT traffic		
Other outgoing calls (wholesale)			



## Structure of the market module

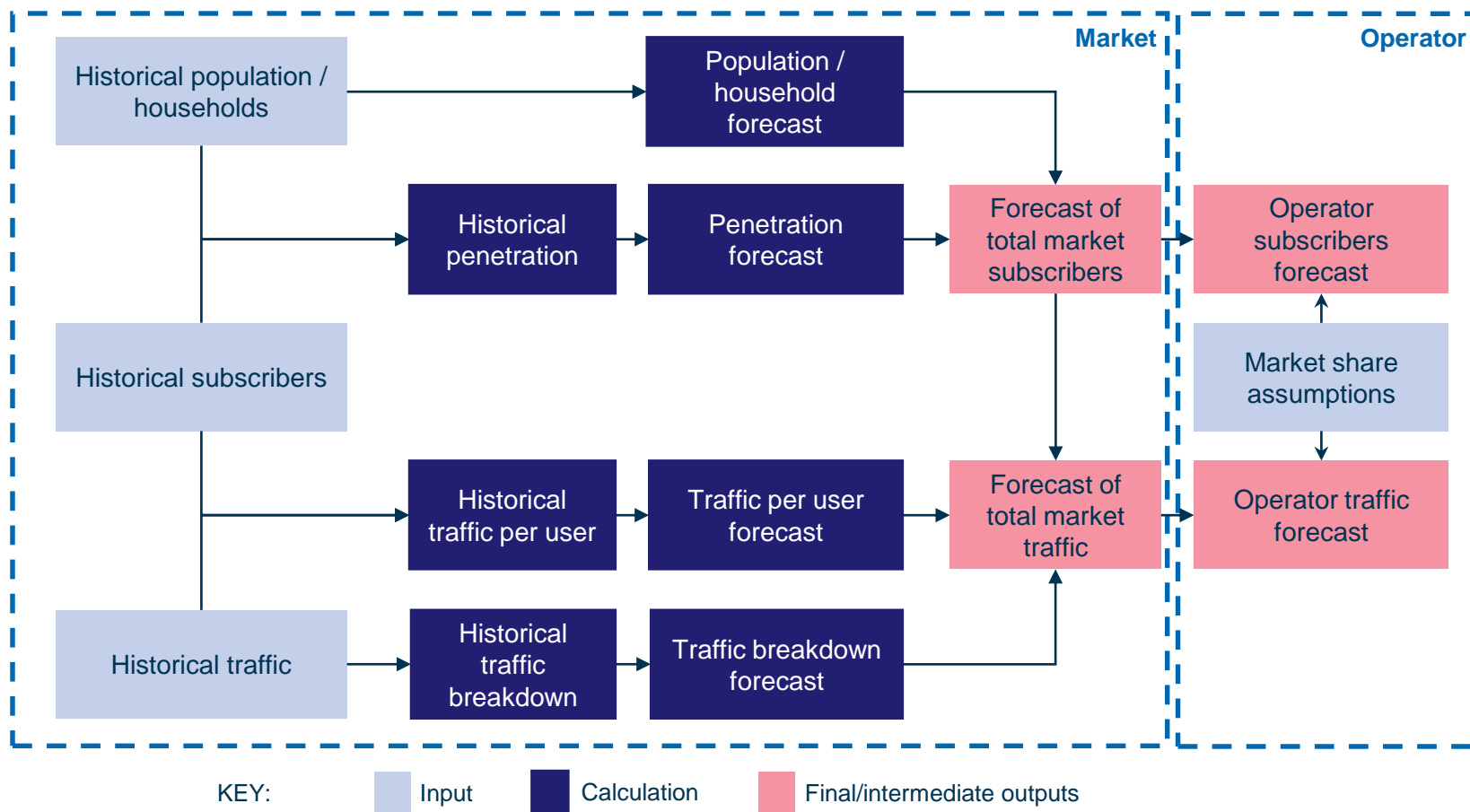

Introduction

Overview of the model

**Market module**

Network design module

Service costing module

Model results

Annexes



Overview of the module

**Voice services**

Data services

Multimedia services

Geotyping approach

## Fixed voice traffic is derived from the average level of traffic per subscriber and the level of penetration of fixed voice services

### High-level flow of calculations to forecast fixed voice traffic in the market module

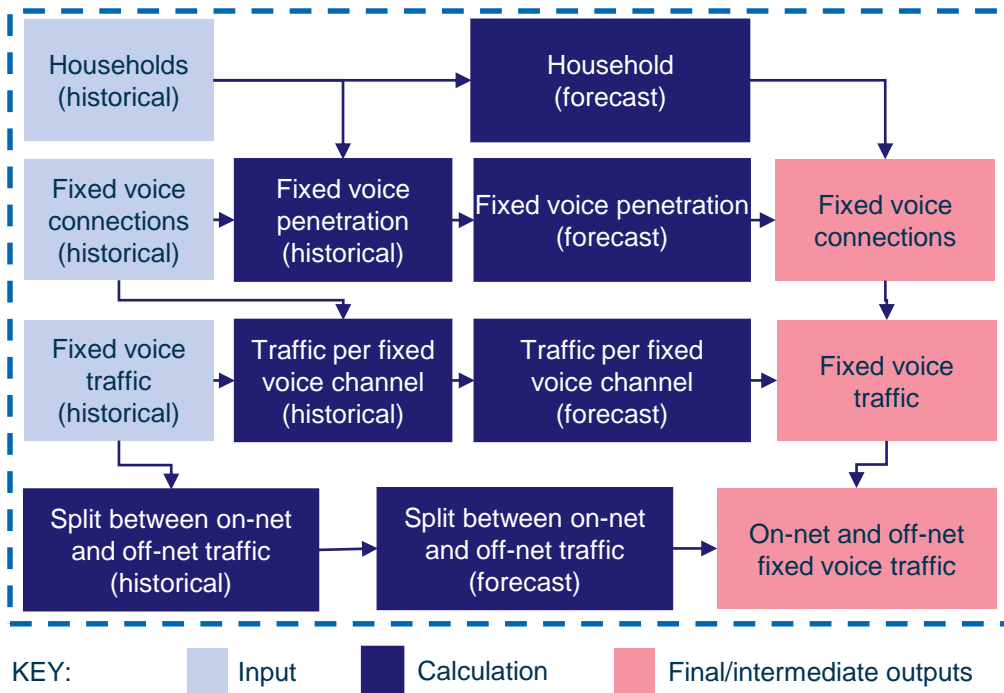

### Methodology used to estimate the number of fixed voice connections:

- the number of fixed voice connections is driven by the number of households and the level of penetration of fixed voice services in Portugal
- we have used forecasts from Euromonitor International to estimate the growth in the number of households in coming years
- the model assumes a slight increase and stabilization in fixed voice penetration, in line with the forecasts from Analysys Mason Research

### Methodology used to estimate fixed voice traffic:

- the average level of voice traffic per fixed connection is derived from historical data
- the model calculates the total fixed voice traffic in Portugal multiplying the average traffic per connection by the number of fixed voice connections



The model assumes a slight increase in fixed voice penetration over the modelled period, in line with market trends

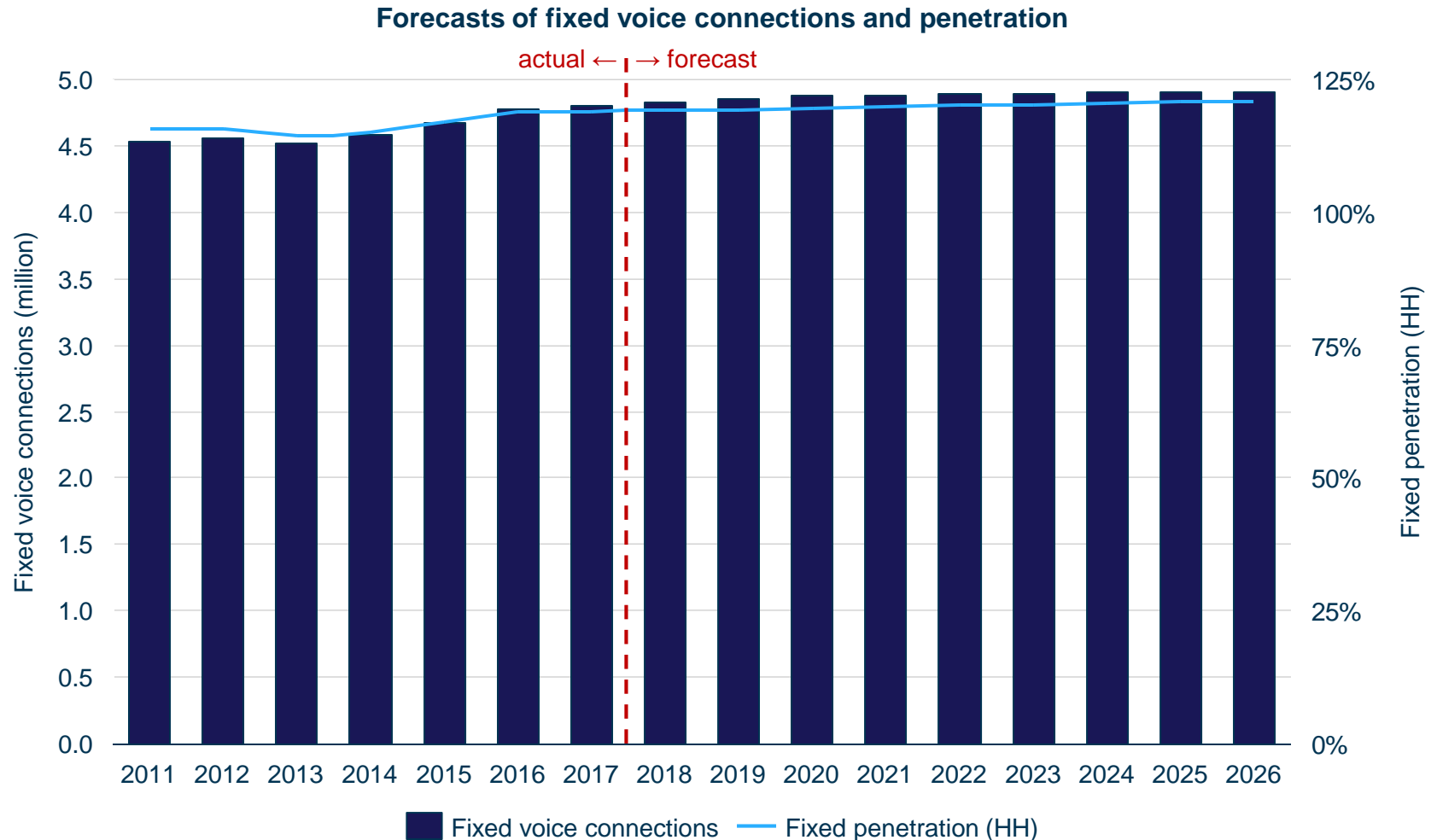

## Fixed outgoing traffic is forecast to slightly decrease over the modelled period

- The average level of voice traffic per fixed connection is derived from historical data:
  - following significant declines in the average level of on-net and off-net traffic per fixed subscriber, and incoming traffic per subscriber, the model assumes a more stable trend in the future

Outgoing and incoming minutes per fixed subscriber

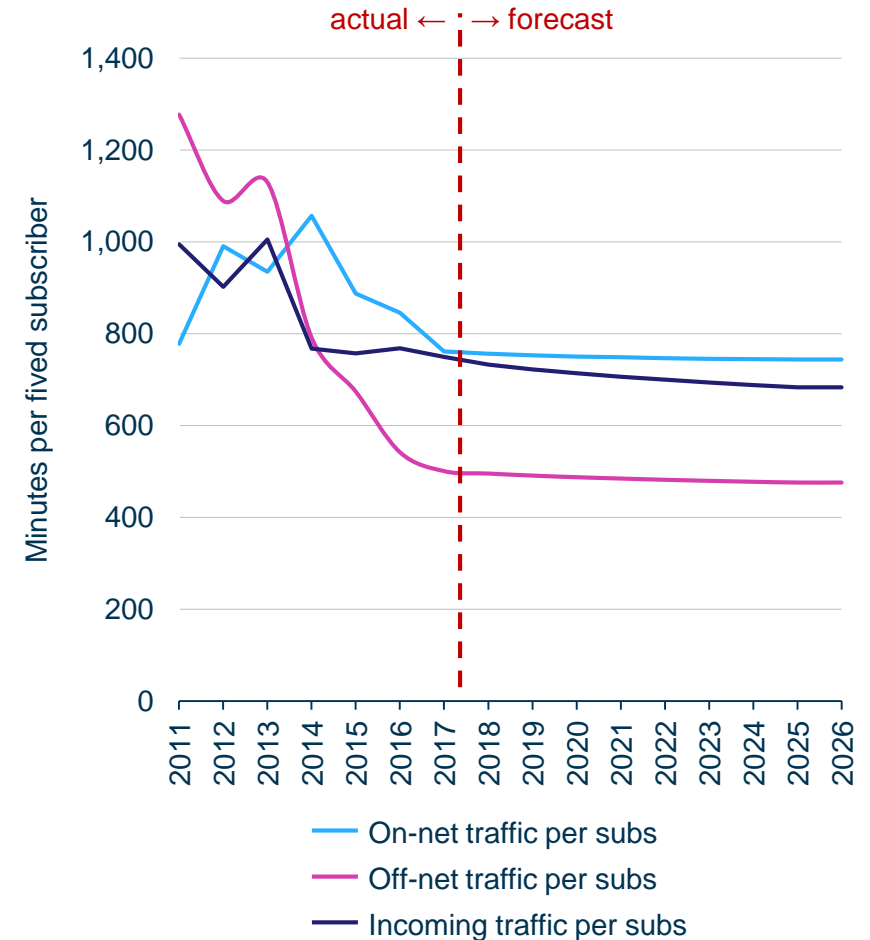



## The fixed voice traffic is further split into on-net and off-net traffic

- The fixed voice traffic is further split into the following sub-services:
  - *on-net traffic*: local, national and non-geographical on-net traffic
  - *off-net traffic*: outgoing calls to mobile, fixed, international and non-geographical numbers
- The average level of traffic per voice sub-service is derived from historical data:
  - we assume that the proportion of traffic per sub-service as a share of total fixed voice traffic follows a similar trend to that observed in previous years
  - the annual level of voice traffic per sub-service is calculated by multiplying the weighted average of each voice sub-service by the total fixed voice traffic

Forecasts of on-net fixed traffic

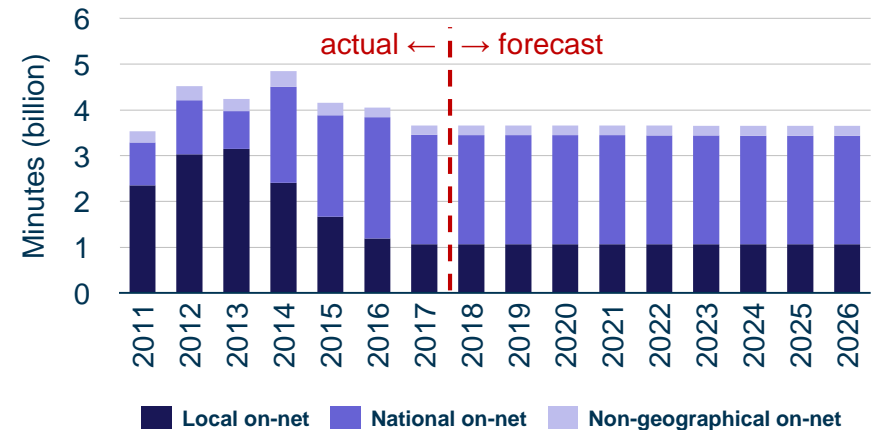

Forecasts of off-net fixed traffic

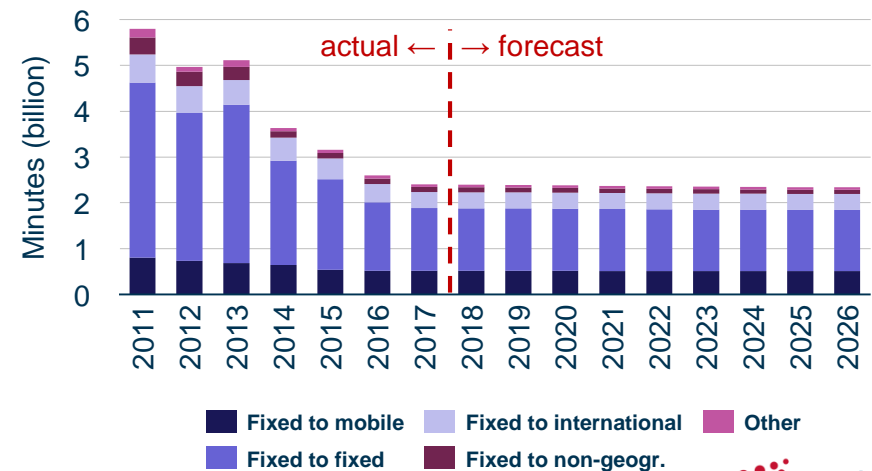

## The model assumes a slight decrease in mobile-to-fixed traffic, in line with market trends and industry forecasts

### High-level flow of calculations to forecast mobile-to-fixed voice traffic in the market module

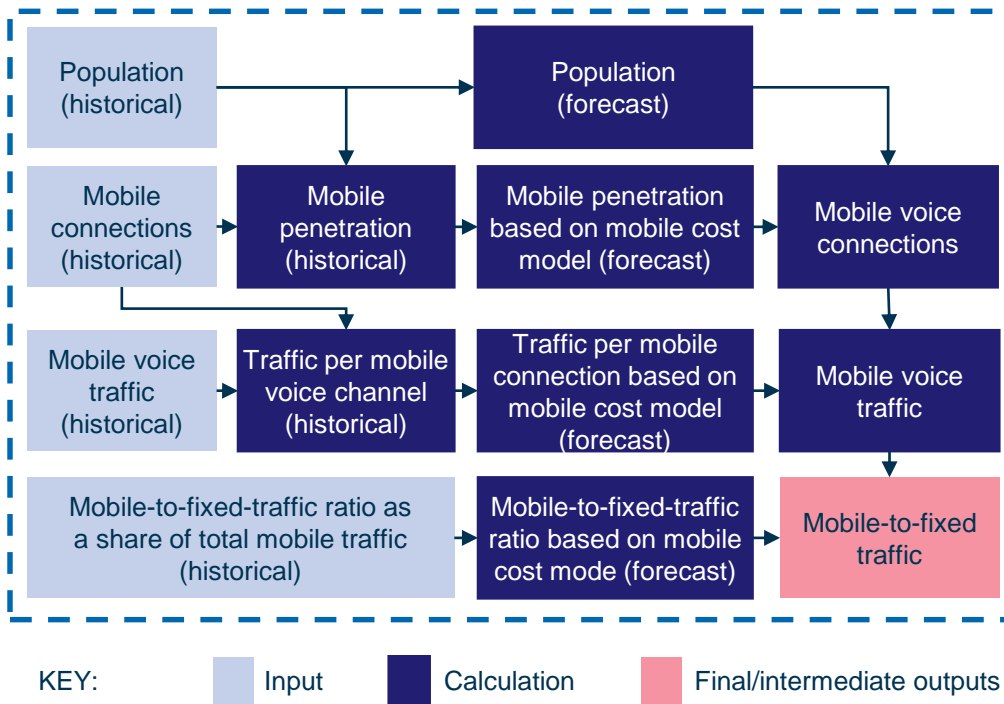

- Mobile traffic is driven by the forecast growth in:
  - population
  - mobile penetration
  - average traffic per mobile subscriber
- We have used the forecasts from Portuguese MTR 2017 model to estimate the growth in population
- The model assumes a decline in mobile penetration, in line with the forecasts of the MTR 2017 model
- Our projections of average traffic per mobile subscriber are derived from historical data

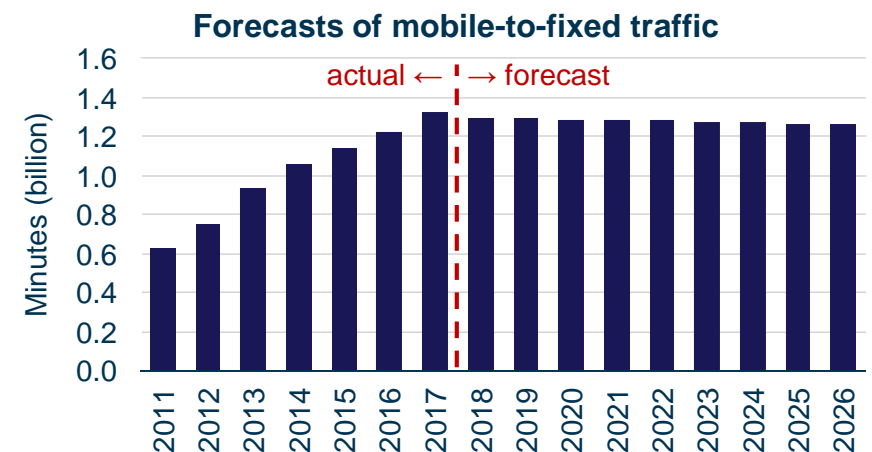

## Incoming traffic is forecast to slightly decrease over the modelled period

### High-level flow of calculations to forecast wholesale incoming traffic in the market module

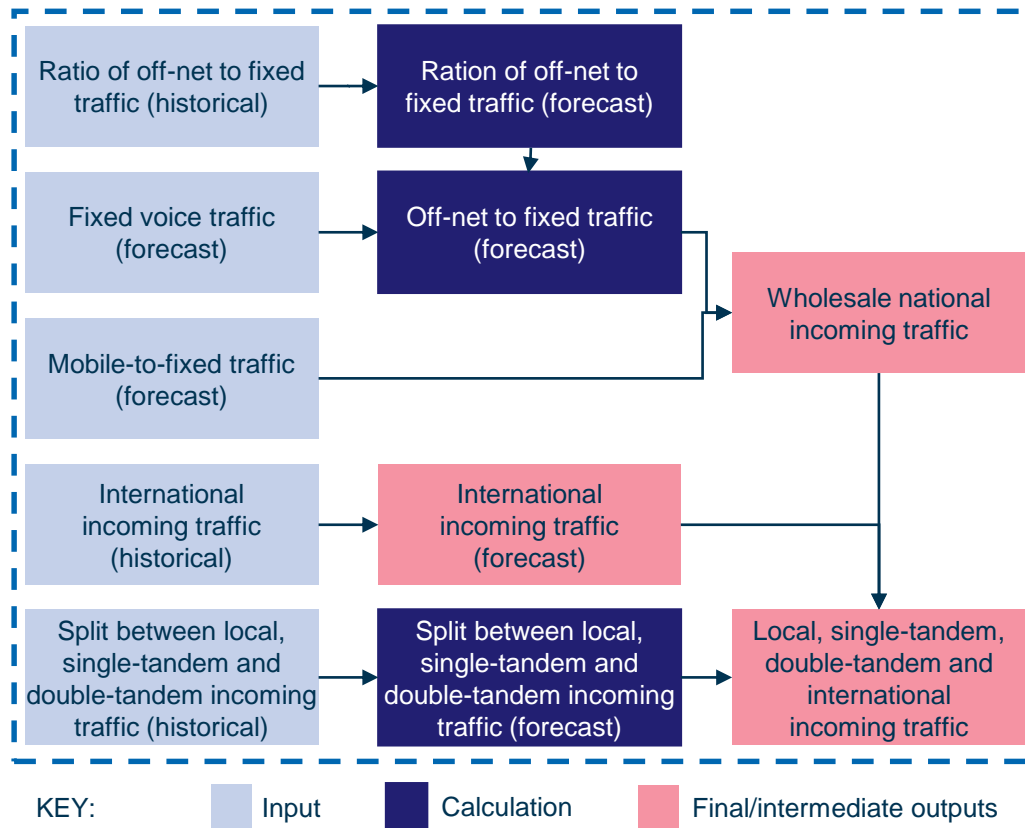

- As described in the previous slides, wholesale national incoming traffic is driven by:
  - outgoing fixed off-net traffic
  - mobile-to-fixed traffic
- Traffic forecast are derived according to and based on the three sub-services for which historical data are reported:
  - local incoming traffic
  - single-tandem incoming traffic
  - double-tandem incoming traffic
- The market module assumes that the proportion of traffic per sub-service as a share of total wholesale incoming traffic follows a similar trend to that observed in previous years
- Traffic forecast do not depend on the interconnection technology (i.e. TDM or IP)

### Forecasts of wholesale national incoming traffic

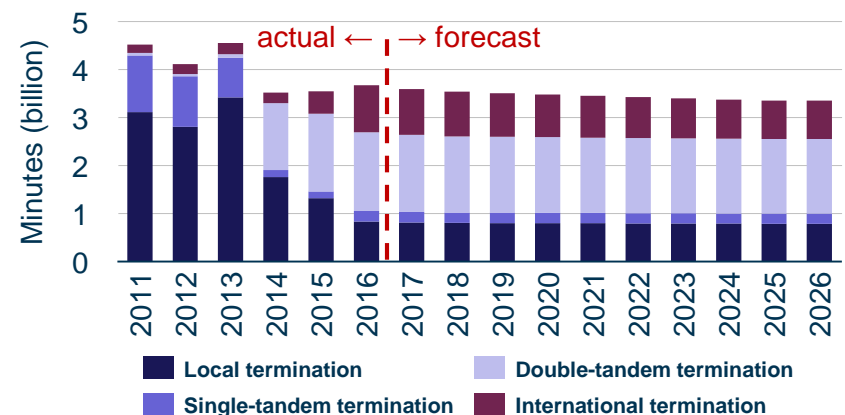



# The wholesale outgoing and transit traffic forecasts are derived from historical data [1/2]

## High-level flow of calculations to forecast wholesale origination traffic in the market module

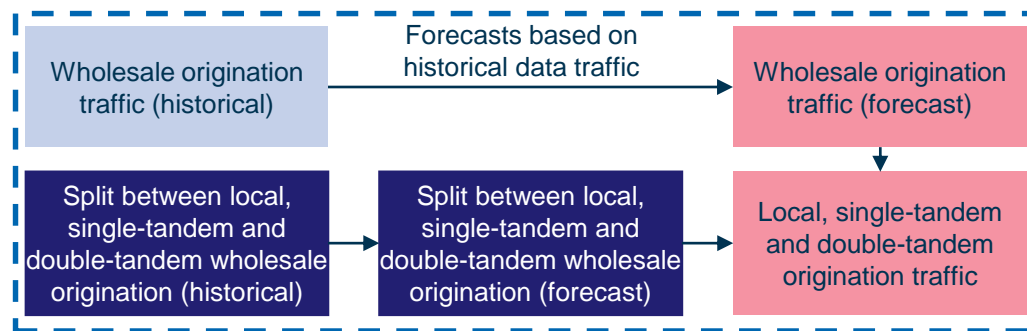

KEY:  Input  Calculation  Final/intermediate outputs

- The wholesale outgoing total traffic forecasts are derived from historical data
- Traffic forecast are derived according to and based on the four sub-services for which historical data are reported:
  - local outgoing traffic
  - single-tandem outgoing traffic
  - double-tandem outgoing traffic
  - other wholesale outgoing traffic
- The market module assumes that the proportion of traffic per sub-service as a share of total wholesale outgoing traffic follows a similar trend to that observed in previous years
- Traffic forecast do not depend on the interconnection technology (i.e. TDM or IP)

## Forecasts of wholesale outgoing traffic

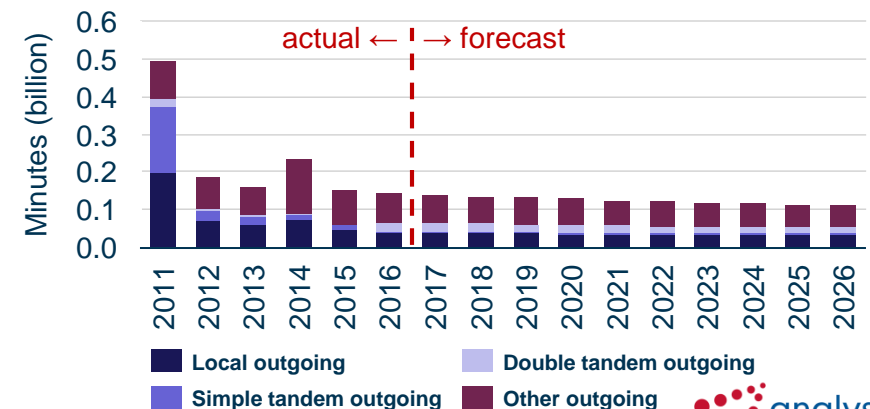

# The wholesale outgoing and transit traffic forecasts are derived from historical data [2/2]

## High-level flow of calculations to forecast wholesale transit traffic in the market module

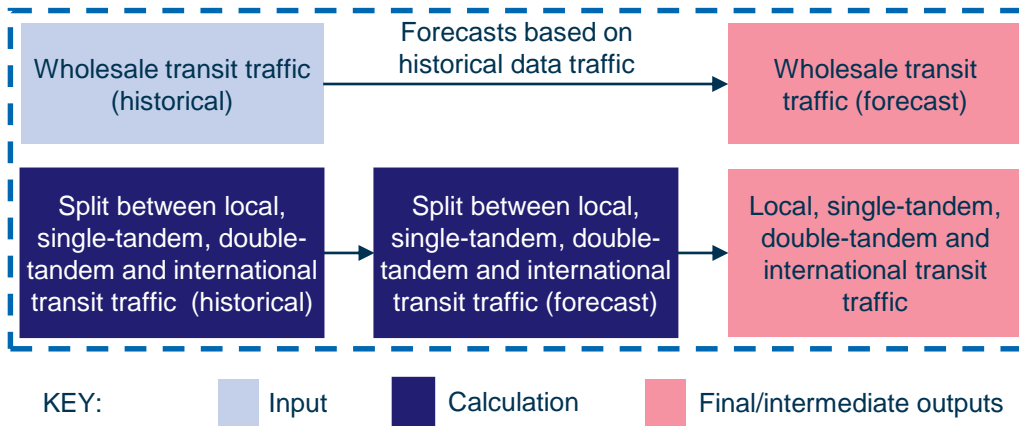

- The wholesale transit total traffic forecasts are derived from historical data
- Based on historical data, wholesale transit traffic is further split into six sub-services:
  - local national transit traffic
  - single-tandem national transit traffic
  - double-tandem national transit traffic
  - national to international and international to national transit traffic
  - international to international transit traffic
  - other transit traffic
- The market module assumes that the proportion of traffic per sub-service as a share of total wholesale transit traffic follows a similar trend to that observed in previous years

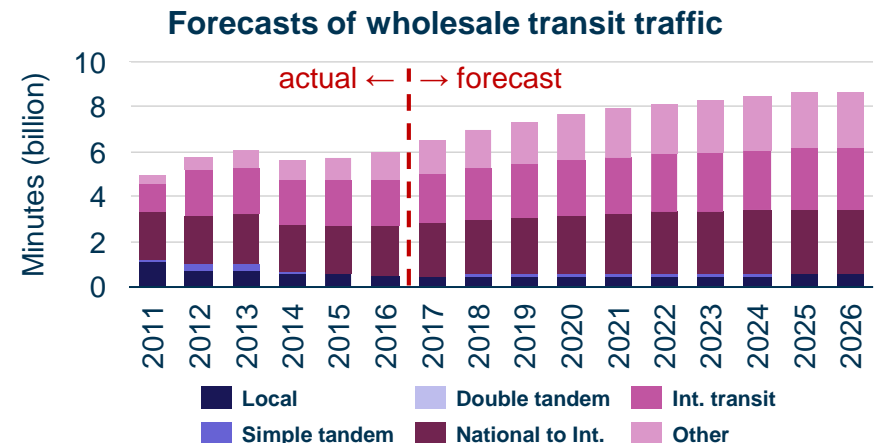

Introduction

Overview of the model

**Market module**

Network design module

Service costing module

Model results

Annexes



Overview of the module

Voice services

**Data services**

Multimedia services

Geotyping approach

# Broadband data traffic is driven by both broadband penetration and the average level of data traffic per subscriber

High-level flow of calculations to forecast broadband data traffic in the market module

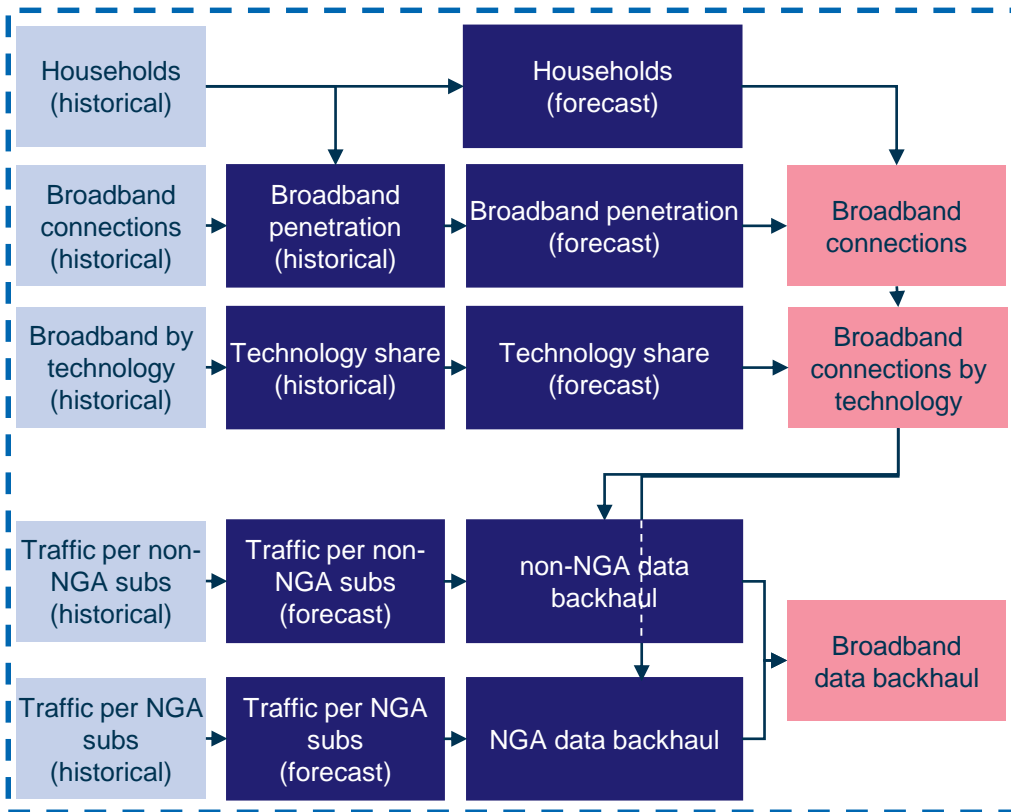

KEY:  Input  Calculation  Final/intermediate outputs

Methodology used to estimate the number of broadband connections by technology:

- we have used forecasts from Euromonitor International to estimate the growth in the number of households over the modelled period (2018–2026)
- we have assumed some growth in broadband penetration, in line with Analysys Mason Research forecasts
- based on the historical number of subscribers per technology, the market is further split into two categories
  - non-NGA subscribers
  - NGA subscribers
- the market module assumes that the average amount of data consumed per NGA subscriber is higher than for traditional broadband subscribers

Methodology used to estimate the average level of broadband data traffic:

- data backhaul requirements are driven by both the number of non-NGA and NGA connections and the average traffic per type of subscriber <sup>(1)</sup>
- traffic per type of subscriber (i.e. non-NGA or NGA) is derived from historical data

<sup>(1)</sup> Non-NGA subscribers include copper and non-DOCSIS 3.0 cable subscribers. NGA subscribers include fibre-to-the-home (FTTH) and DOCSIS 3.0 cable subscribers



# Broadband subscriber numbers and average data consumption per subscriber are forecast to grow over the modelled period

Forecasts of fixed broadband subscribers and penetration

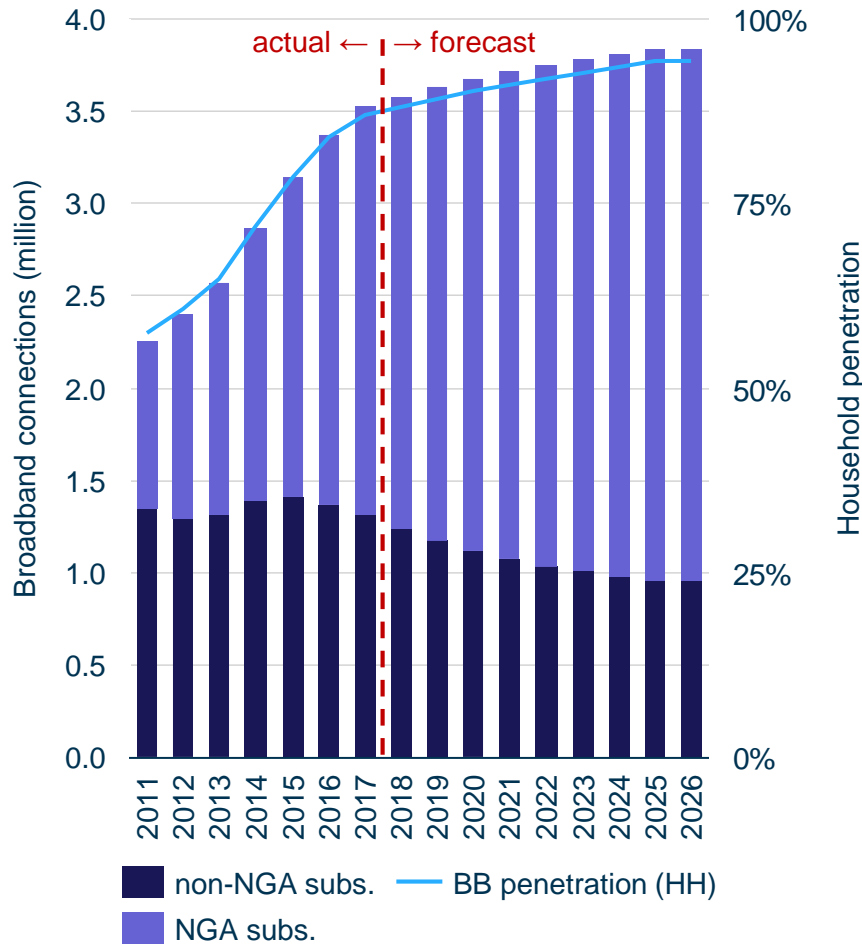

Forecasts of broadband consumption per type of subscriber

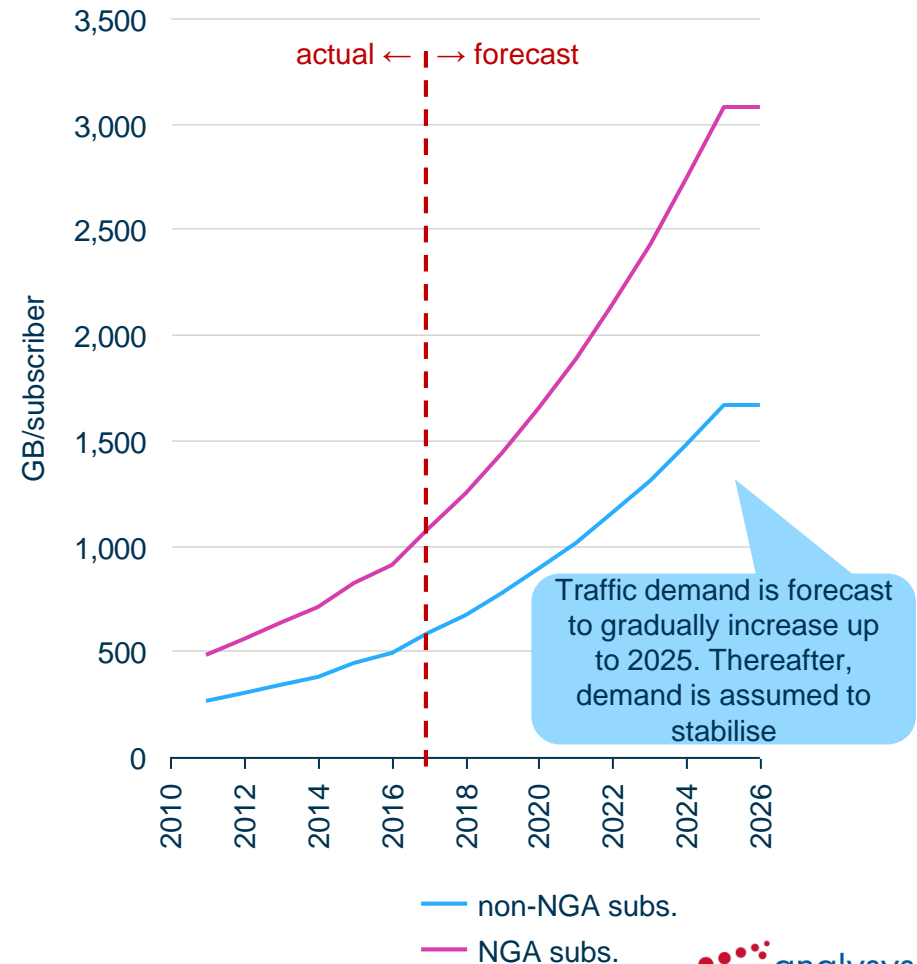

Introduction

Overview of the model

**Market module**

Network design module

Service costing module

Model results

Annexes



Overview of the module

Voice services

Data services

**Multimedia services**

Geotyping approach

## A similar methodology is used to estimate the number of pay-TV, VoD and OTT subscribers in Portugal

### High-level flow of calculations to forecast the number of pay-TV connections in the market module

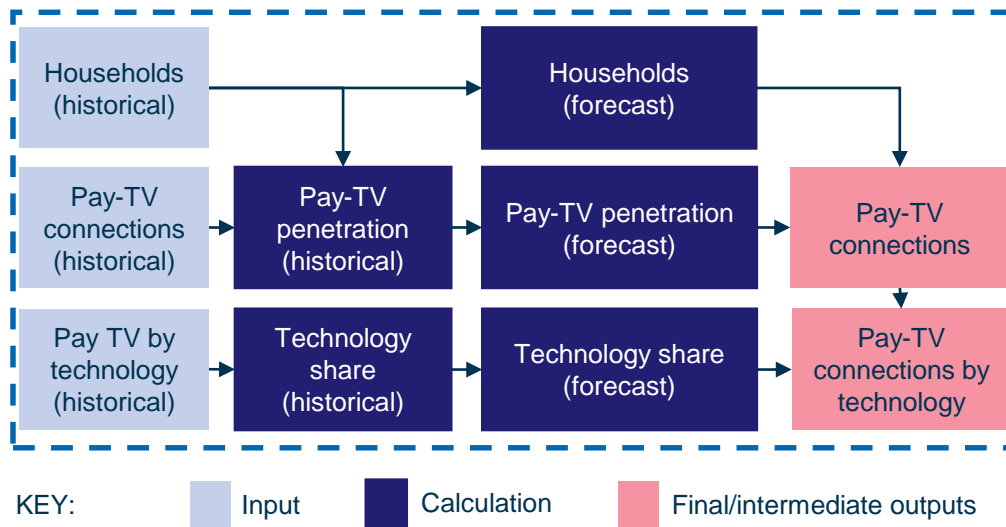

### Methodology to estimate the number of pay-TV subscribers by technology:

- the primary growth drivers for pay-TV connections appear to be the number of households and the level of pay-TV penetration
- we have used forecasts from Euromonitor International to estimate the growth in the number of households over the modelled period
- our pay-TV market forecasts have been derived from Analysys Mason Research forecasts; these are split into four categories
  - cable TV
  - direct-to-home (DTH)
  - fibre-to-the-home (FTTH) IPTV
  - xDSL IPTV
- the number of pay-TV subscribers per technology is then calculated by multiplying the total number of pay-TV subscribers by the share of cable TV, FTTH and xDSL subscribers

### Methodology to estimate the number of VoD and OTT subscribers:

- the number of VoD and OTT subscribers in Portugal over the modelled period is derived from Analysys Mason Research forecasts



# Take-up of VoD and OTT services is expected to grow rapidly

Forecasts of IPTV and cable TV subscribers and penetration

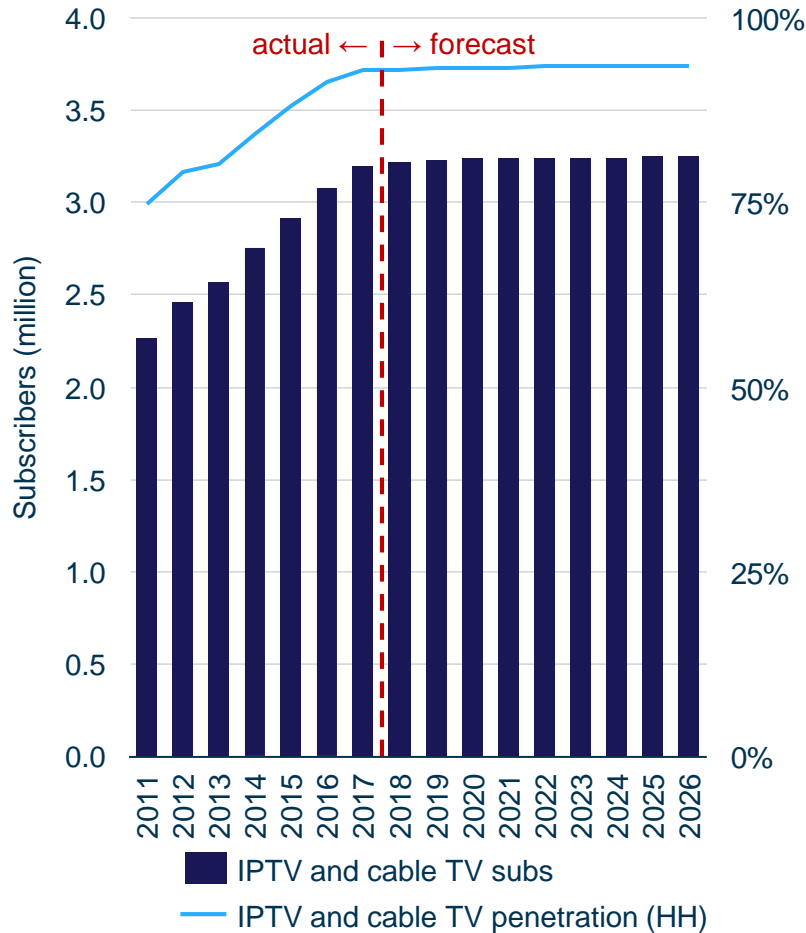

Forecasts of VoD and OTT subscribers

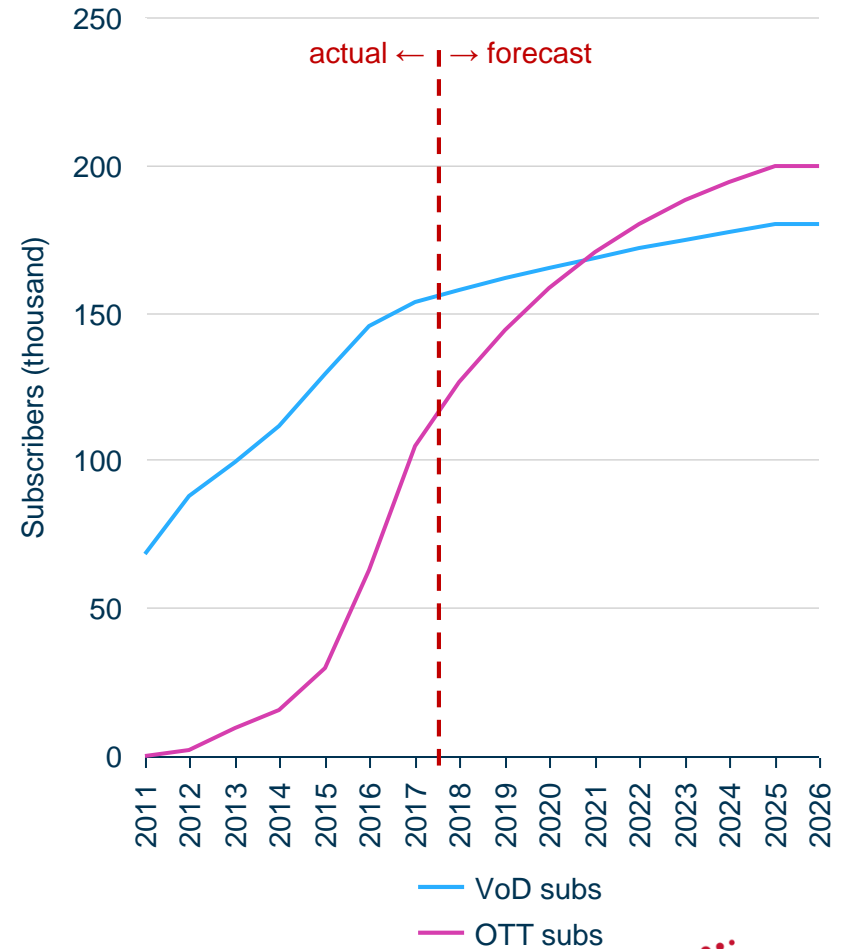



Introduction

Overview of the model

**Market module**

Network design module

Service costing module

Model results

Annexes



Overview of the module

Voice services

Data services

Multimedia services

**Geotyping approach**

# The *concelhos* in Portugal have been classified into four sets of geotypes [1/3]

- Based on this, we have split Portugal into four geotypes:
  - **Geotype 1:** *concelhos* where 3 or more fixed operators are present
  - **Geotype 2:** *concelhos* where MEO and cable operators are present, but not FTTH
  - **Geotype 3:** *concelhos* where only MEO is present, or MEO and FTTH operators
  - **Geotype 4:** Portuguese islands, i.e. archipelagos of Madeira and Azores
- The geotypes are defined based on the:
  - *number of fixed operators per concelho* (e.g. geotype 1 covers the areas with a greater number of fixed operators)
  - *access technologies per concelho* (e.g. cable operators are not present in geotype 3)
  - *migration from copper to fibre*
  - *geographical diversity of Portugal* (e.g. this approach permits to deploy a different architecture in the islands)
- This approach allows to:
  - test the impact of having different traffic volumes in the geotypes considered

## Proposed geotyping

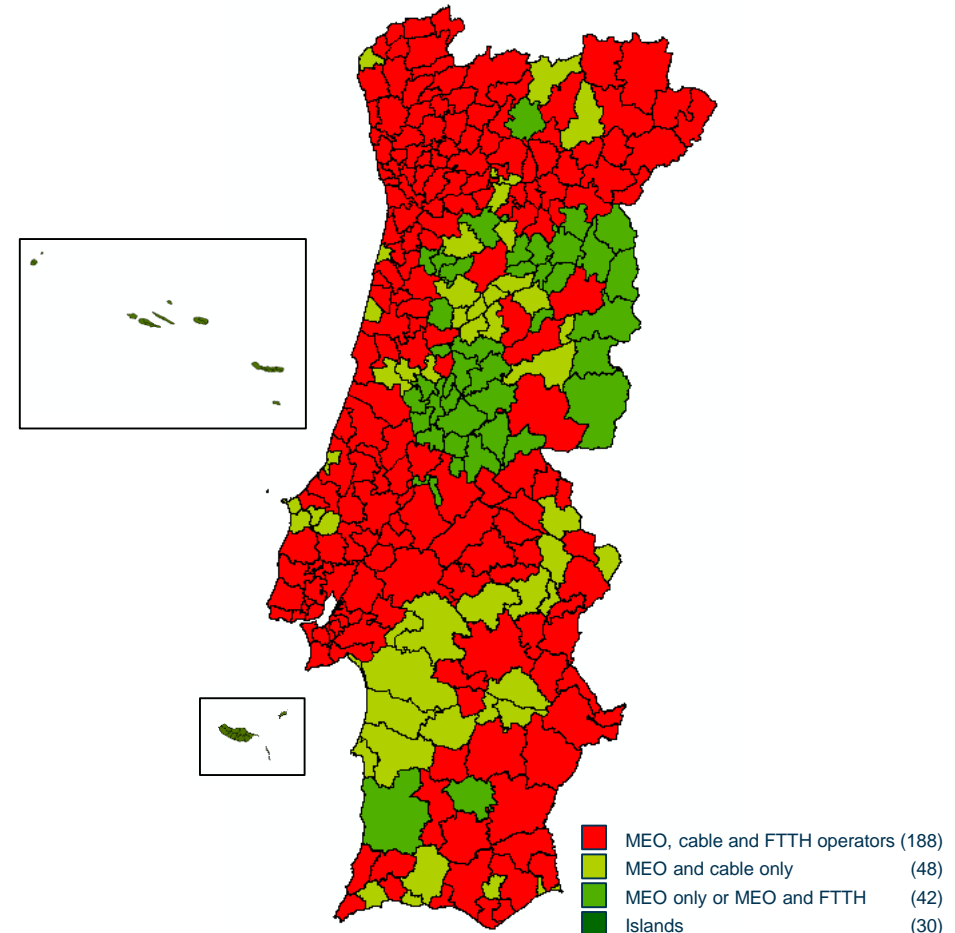



## The *concelhos* in Portugal have been classified into four sets of geotypes [2/3]

Subscribers per service and geotype (2017)

<i>Geotype</i>	<i>Voice subscribers</i>	<i>Broadband subscribers</i>	<i>Broadband non-NGA subscribers</i>	<i>Broadband NGA subscribers</i>	<i>Cable TV + IPTV subscribers</i>
Geotype 1	4,138,762	3,082,178	1,092,791	1,989,387	2,760,079
Geotype 2	307,143	199,652	107,797	91,855	168,945
Geotype 3	113,926	50,545	26,755	23,790	26,114
Geotype 4	242,294	175,914	77,212	98,702	185,812
<b>Total</b>	<b>4,802,125</b>	<b>3,508,289</b>	<b>1,304,555</b>	<b>2,203,734</b>	<b>3,140,950</b>



# The *concelhos* in Portugal have been classified into four sets of geotypes [3/3]

Forecasts of fixed voice connections per geotype

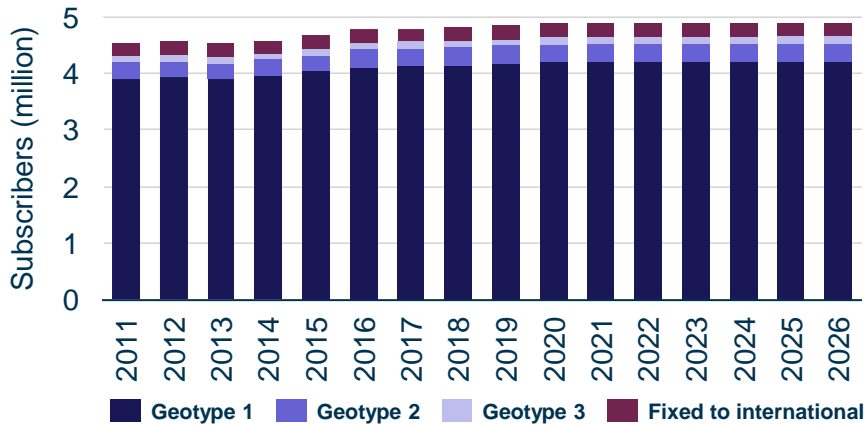

Forecasts of broadband non-NGA subscribers per geotype

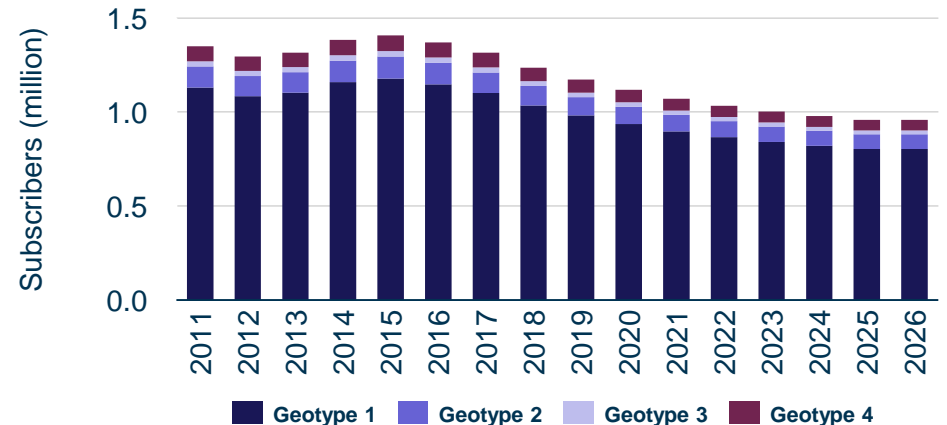

Forecasts of fixed IPTV subscribers per geotype

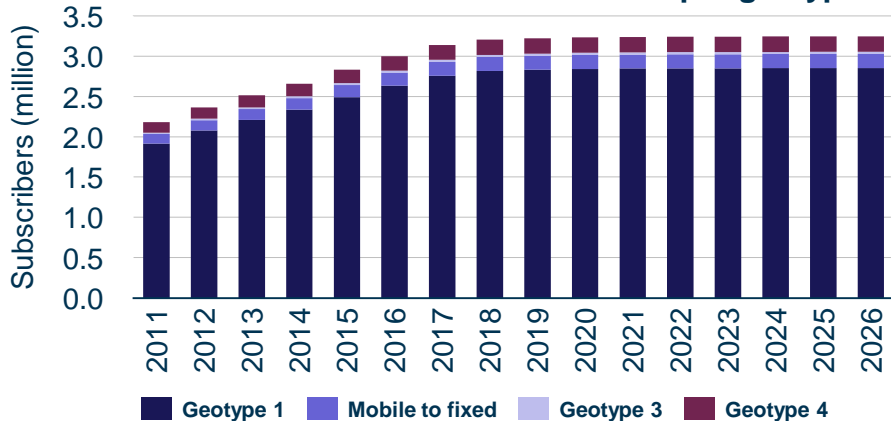

Forecasts of broadband NGA subscribers per geotype

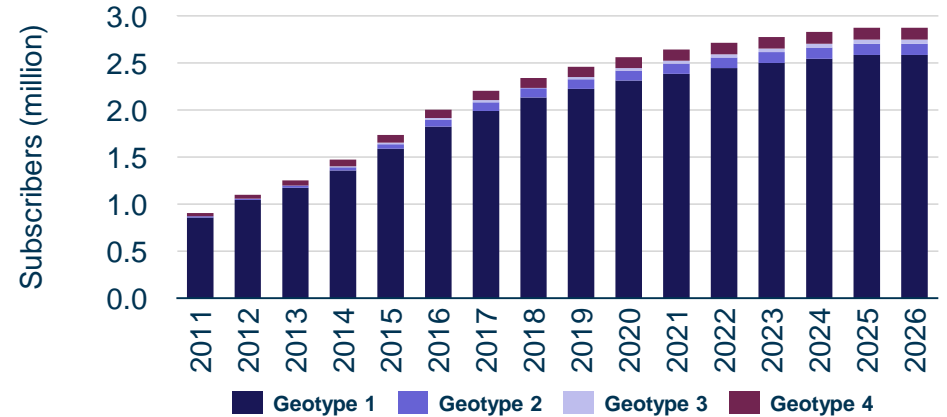

The number of voice, broadband and IPTV subscribers per geotype have been derived from historical data

## The modelled operator is assumed to reach a market share of $1/n$ , where $n$ is the number of fixed operators with significant presence in each geotype

- The model assumes that the operator reaches a market share of  $1/n$ , where  $n$  is equal to the number of fixed operators with significant presence in each geotype:
  - **Geotype 1:** in this geotype there are primarily three competing providers (MEO, the cable operators<sup>(1)</sup> and the alternative operators that have built an FTTH network<sup>(2)</sup>)
    - a three-player market in this geotype seems reasonable; based on this, the model assumes that the operator reaches a market share of 33% in 2013
  - **Geotype 2:** in this geotype there are primarily two competing providers (MEO and the cable operators<sup>(1)</sup>)
    - a two-player market in this geotype seems reasonable; based on this, the model assumes that the operator reaches a market share of 50% in 2013
  - **Geotype 3:** in this geotype there is currently only one service provider (MEO); however, in addition to MEO's network, a neutral operator is rolling out a new FTTx network in the municipalities within this geotype, which is expected to be launched during 2014
    - a two-player market in this geotype seems reasonable in the long run; based on this, the model assumes that the operator reaches a market share of 50% in 2014
  - **Geotype 4:** in this geotype there are primarily two competing providers (MEO and the cable operators<sup>(1)</sup>)
    - a two-player market in this geotype seems reasonable; based on this, the model assumes that the operator reaches a market share of 50% in 2013
- The market share of the modelled operator is then multiplied by the total amount of traffic per service in order to derive the traffic demand for the modelled operator:
  - the growth in voice traffic for a given operator is proportional to its market share and the overall size of the market

(1) *The combined network of the cable operators covers most of the households in geotypes 1, 2 and 4, with little overlap between the different networks*

(2) *Both MEO and the alternative operators are building their own FTTH networks. MEO already covers about two thirds of the households in Portugal with fibre, while the alternative operators have entered into agreements to roll out FTTH networks in the main cities of Portugal*

## The calculated traffic demand feeds into the network design module

Structure of the fixed cost model

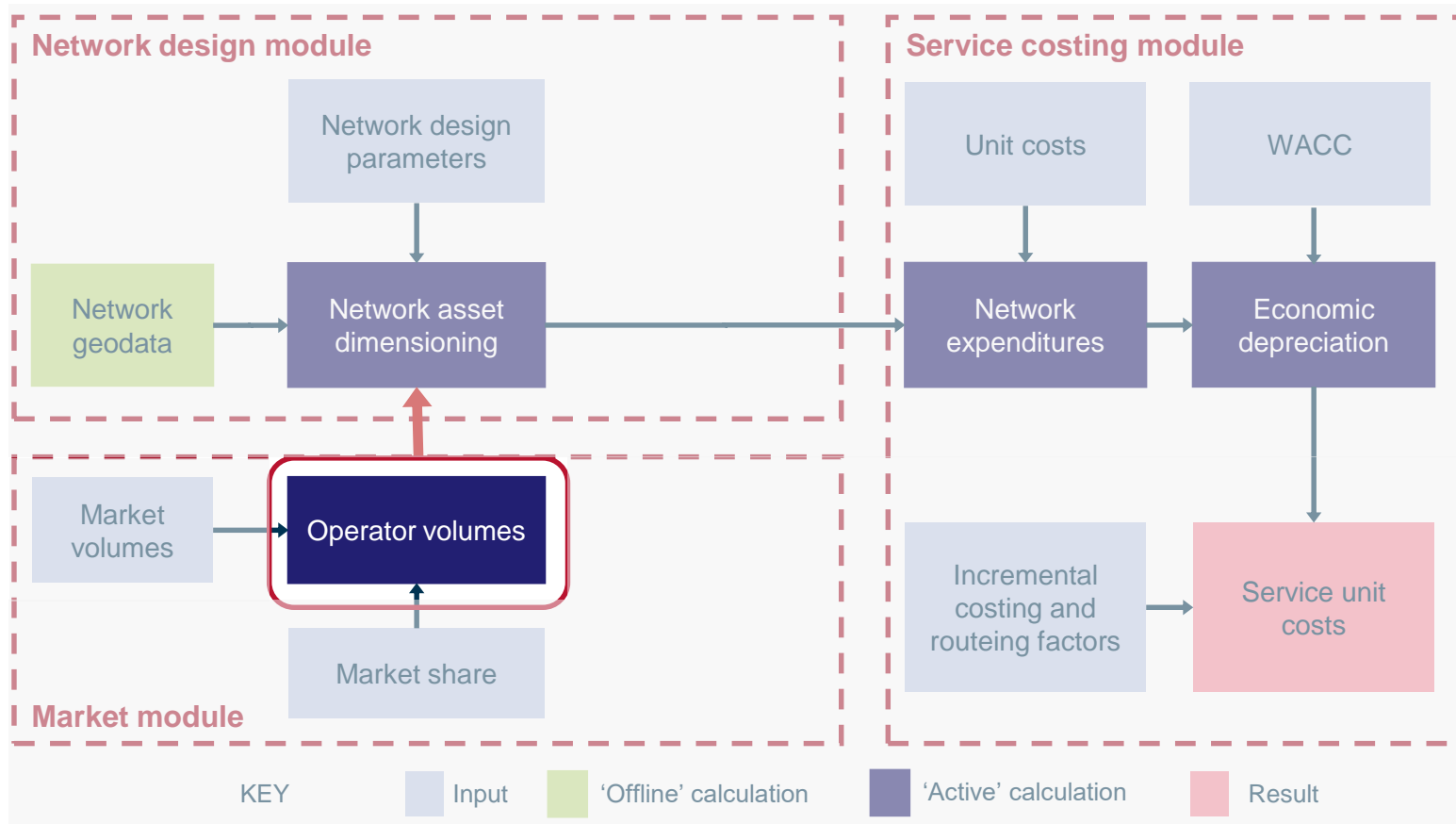

Introduction

Overview of the model

Market module

**Network design module**

Service costing module

Model results

Annexes

**Overview of the network architecture**

Demand conversion

Physical design of the network

Access network

Aggregation network

Core network

# The NGN/IP core network of the modelled operator consists of four layers

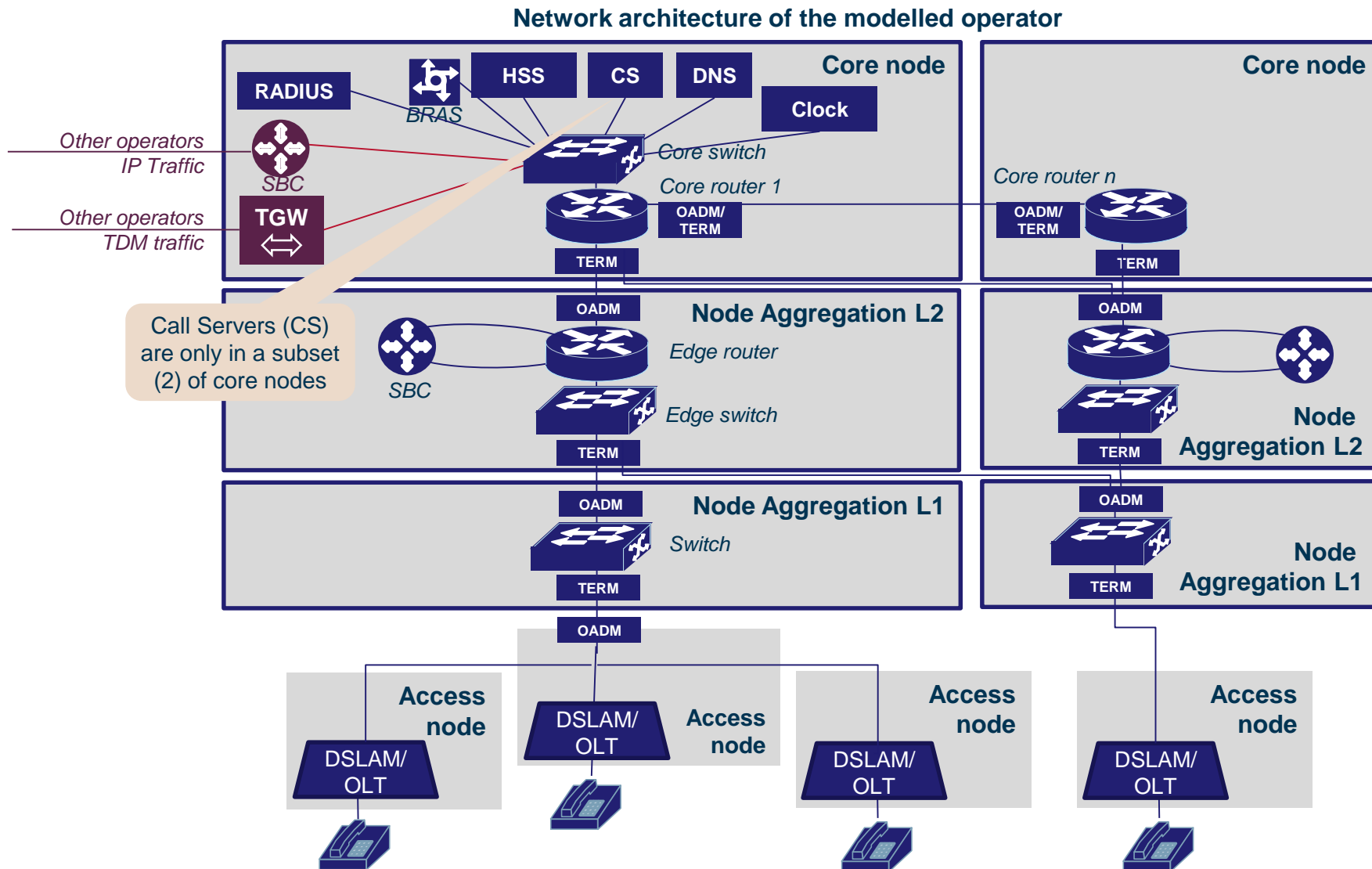



## The access layer is responsible for aggregating the traffic received from the end subscribers and for transmitting it to the core network

- The modelled fixed access layer is based on copper/fibre technology. Migration from copper to fibre has been modelled taking into account the NGA roll-outs of the fixed operators in Portugal
- The **access layer** is responsible for aggregating the traffic received from the end subscribers and for transmitting it to the core network, and *vice versa*:
  - the first point of concentration of traffic is located at the line cards of the DSLAMs / OLTs, located in the local exchanges
  - *DSLAMs*: it multiplexes the traffic from non-NGA subscribers onto the core network
  - *OLTs*: it multiplexes the traffic from the NGA subscribers onto the core network <sup>(1)</sup>
  - the number of access nodes is equal to the number of local exchanges of MEO (i.e. 1669)

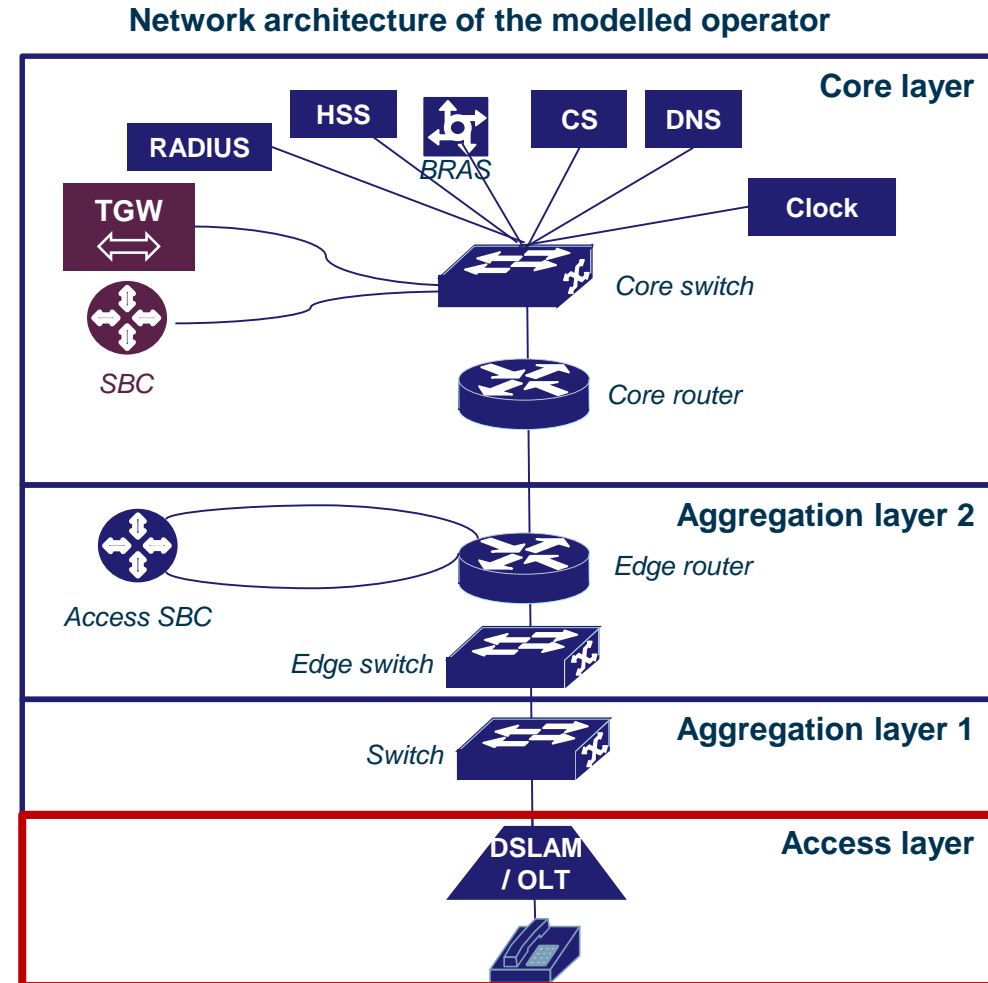

## The aggregation layer of the modelled operator consists of two different layers, which improves the resilience of the network

- The aggregation layer of the modelled operator consists of two different layers. This architecture improves the resilience of the network, reducing the number of subscribers that could be affected by a failure of an aggregation node
- The **first aggregation layer** contains the first level of switching:
  - *Ethernet switch*: it is used to aggregate the traffic
  - the first aggregation layer consists of 166 nodes
- The **second aggregation layer** contains the second level of switching, the edge routers and the access session border controller (SBC):
  - *Ethernet switch*: it is used to aggregate the traffic
  - *edge router*: it is used for routing the traffic from the access layer to the core nodes or to another DSLAM / OLT located within the same aggregation node, and *vice versa*. The edge routers are capable of transmitting local on-net calls to a receiver within the same area (without reaching the core layer)
  - *SBC*: it provides security between the different network domains (e.g. network address translation, stopping denial of service attacks, etc.) and controls the bandwidth allocation per call or per session
  - the second aggregation layer consists of 25 nodes

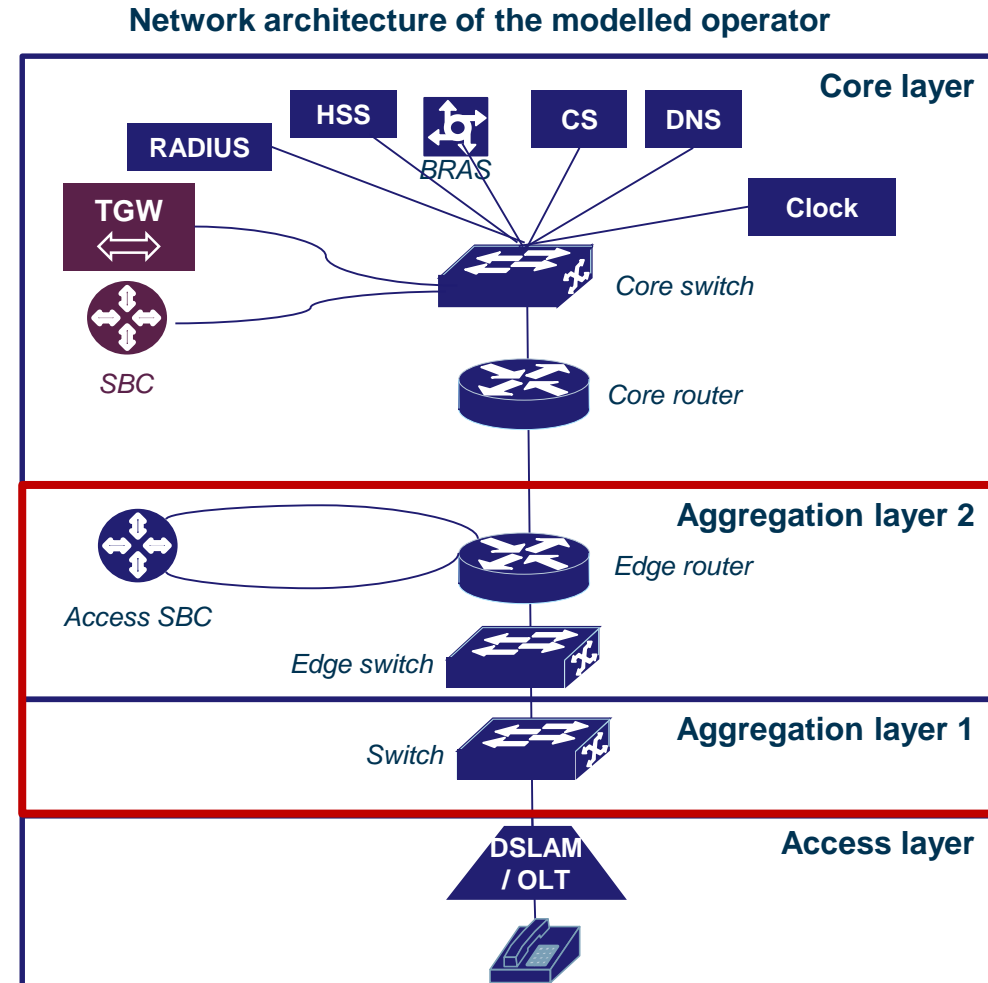

## The core layer is responsible for managing and distributing the traffic nationwide and hosts the IMS equipment: *Traffic resources*

- The core layer is responsible for managing and distributing the traffic nationwide
- The model assumes that the number of core nodes is equal to five, located in Lisbon (three) and Porto (two)
- The main assets deployed in the core network are:
  - *core router*: it is used for routing the traffic between aggregation and core nodes, and between core nodes
  - *core switch*: it is used to connect the voice, data and interconnection platforms with the core network
  - *interconnection platforms*
    - interconnection points are located in each core node; of the five core nodes, two also have international connectivity
    - the operator uses two types of resources depending on the type of interconnection traffic
      - *trunking gateway (TGW)*: it translates the TDM-based voice coming from other networks to IP for transit over the next-generation core network, and *vice versa*
      - *SBC*: it monitors the IP interconnection traffic and manages the quality of service (QoS) of the interconnection traffic

Network architecture of the modelled operator

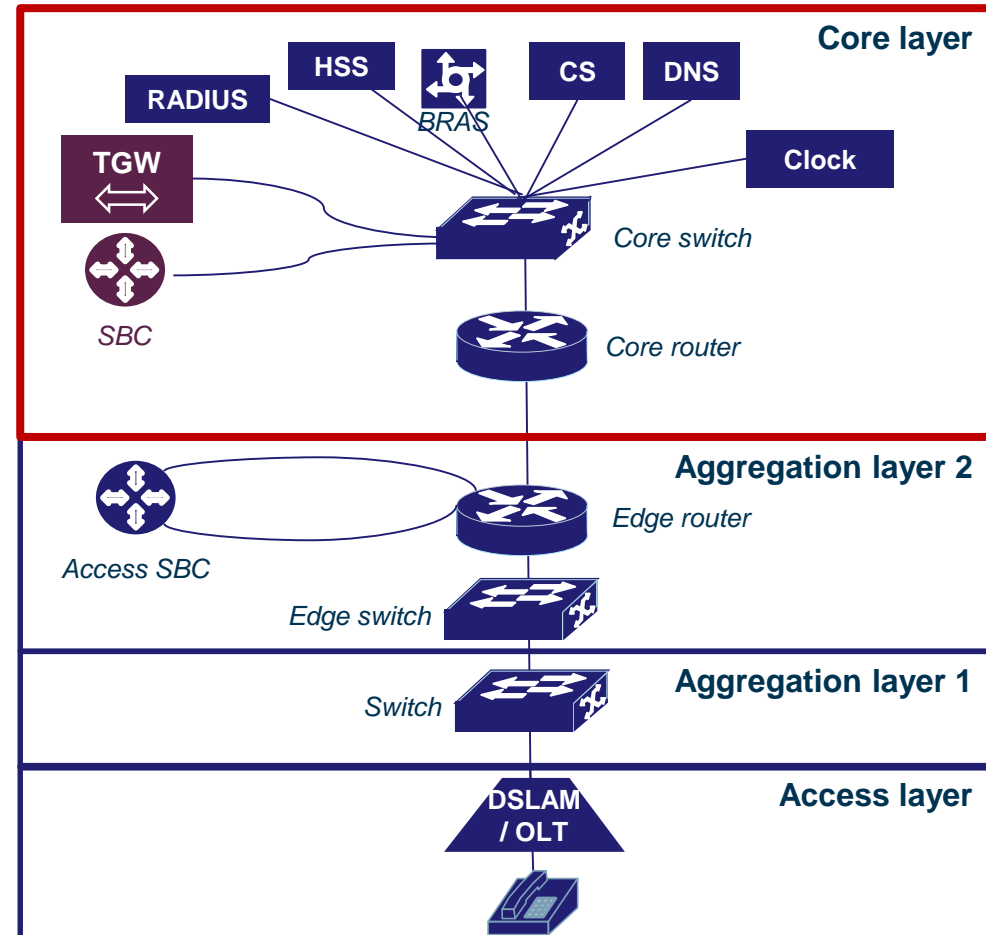



## The network design module uses a combination of inputs from ANACOM, operator data and Analysys Mason estimates [1/2]

### Main inputs used in the network design module

Parameter	Source
Busy days per year	Analysys Mason estimates
Proportion of weekly traffic during busy days	Analysys Mason estimates, operator data
Proportion of daily traffic during the busy hour	Analysys Mason estimates, operator data
Call attempts per successful call	Analysys Mason estimates, operator data
Voice codec	Analysys Mason estimates, operator data
IP/VPN contention ratio	Analysys Mason estimates, operator data
Average call duration	ANACOM
Local exchanges per geotype	ANACOM
Parent local exchanges per geotype	Analysys Mason estimates, operator data

## The network design module uses a combination of inputs from ANACOM, operator data and Analysys Mason estimates [2/2]

### Main inputs used in the network design module

Parameter	Source
Technical parameters to dimension DSLAMs	Analysys Mason estimates, operator data
Technical parameters to dimension OLTs	Analysys Mason estimates, operator data
Technical parameters to dimension access rings	Analysys Mason estimates, operator data
Technical parameters to dimension Ethernet switches	Analysys Mason estimates, operator data
Technical parameters to dimension edge routers	Analysys Mason estimates, operator data
Technical parameters to dimension access SBCs	Analysys Mason estimates, operator data
Technical parameters to dimension aggregation rings	Analysys Mason estimates, operator data
Technical parameters to dimension core routers	Analysys Mason estimates, operator data
Technical parameters to dimension core switches	Analysys Mason estimates, operator data
Technical parameters to dimension TGWs	Analysys Mason estimates, operator data
Technical parameters to dimension SBCs for interconnection	Analysys Mason estimates, operator data
Technical parameters to dimension core rings	Analysys Mason estimates, operator data
Technical parameters to dimension other network platforms (e.g. DNS, BRAS)	Analysys Mason estimates, operator data

Introduction

Overview of the model

Market module

**Network design module**

Service costing module

Model results

Annexes

Overview of the network architecture

**Demand conversion**

Physical design of the network

Access network

Aggregation network

Core network

# The traffic demand forecasts from the market module are converted into busy-hour traffic

## High-level flow of calculations to derive the traffic in the busy hour

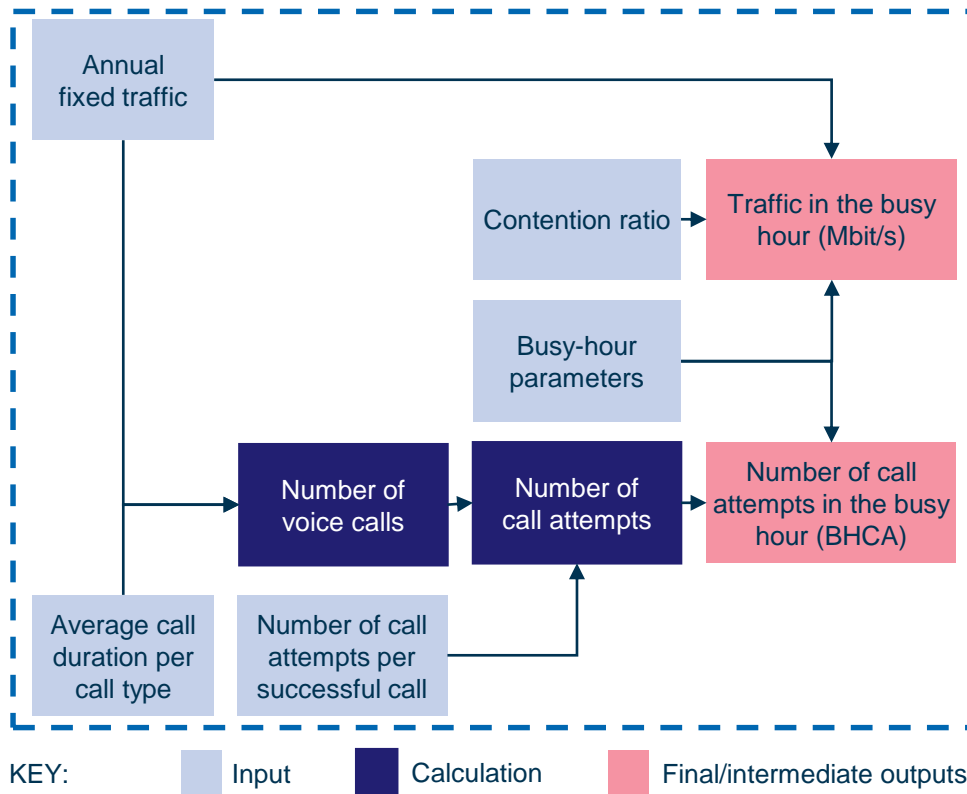

### Methodology to estimate the traffic in the busy hour:

- the annual voice and data traffic forecasts from the market module are then converted into busy-hour traffic (BH Mbit/s) using the appropriate busy-hour and contention ratio parameters

### Methodology to estimate the number of call attempts in the busy hour:

- the number of voice calls is obtained by dividing the annual voice traffic by the average call duration per successful call
- the total number of call attempts is calculated by multiplying the number of voice calls by the average number of call attempts per successful call
- finally, the total number of call attempts in the year is then converted into a further measure, namely the number of busy-hour call attempts (BHCA) using the appropriate busy-hour parameters



## The volume of traffic and the number of call attempts in the busy hour are calculated using the following inputs

### Busy-hour parameters

Parameter	Voice	Data	Source
Busy days per year	250	365	Analysys Mason* estimates
Proportion of weekly traffic during busy days	<b>DATA REMOVED TO PROTECT CONFIDENTIAL OPERATOR INFORMATION</b>		Analysys Mason estimates, operator data
Proportion of daily traffic during the busy hour			Analysys Mason estimates, operator data
Call attempts per successful call		N/A	Analysys Mason estimates, operator data
Voice codec**	G711 20ms (95kbit/s)	N/A	Analysys Mason estimates, operator data
IP/VPN contention ratio	N/A***	20	Analysys Mason estimates, operator data

\*Analysys Mason

\*\*The model also allows to test the impact of using other voice codecs (e.g. G.729 10ms or G.711 10ms)

\*\*\*Not available

### Average call duration per call type

Parameter	Average call duration (min)	Source
On-net calls	6.9	ANACOM
Non-geographical on-net calls	3.7	ANACOM
Outgoing calls to mobile	1.8	ANACOM
Outgoing calls to other fixed operators (retail)	3.1	ANACOM
Outgoing calls to international numbers (retail)	6.5	ANACOM
Incoming calls to non-geographical numbers	3.7	ANACOM
Local, single-transit and double-transit incoming calls	4.3	ANACOM
International incoming calls	6.5	ANACOM
Outgoing calls (wholesale)	4.3	ANACOM
Outgoing calls to non-geographical numbers (wholesale)	3.7	ANACOM
Local, single-transit and double-transit calls	4.3	ANACOM
International transit calls	6.5	ANACOM

## The dimensioning of the IPTV traffic is based on a long tail distribution to estimate the audience of 185 channels

- The IPTV traffic per network layer is driven by the following factors:
  - number of IPTV subscribers simultaneously connected
  - number of nodes with IPTV subscribers
  - number of channels to be routed
  - bandwidth per channel:
- The model assumes an IPTV offer of 185 channels and an audience distribution based on the Zipf statistical distribution:
  - the first 4 channels have a market share of c. 75% of the audience. All the others represent the 'long tail' of the distribution
  - the number of HD channels broadcasted is expected to reach 55 channels by 2025
- Based on the data provided by the operators, we have assumed that an SD channel needs a bandwidth of 3 Mbit/s, while an HD one needs 6 Mbit/s
- The most popular channels are distributed in *multicast* (all at the same time) and the other ones in *unicast* (the signal is only broadcasted when it is requested by a subscriber), optimising the bandwidth required to transmit the IPTV channels
  - this architecture is based on the information provided by the Portuguese fixed operators

Distribution of the share of audience of the 30 main TV channels

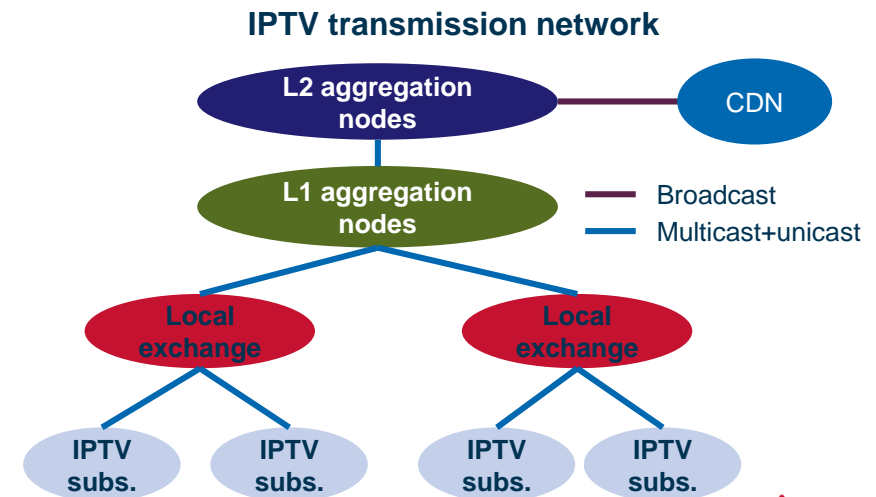
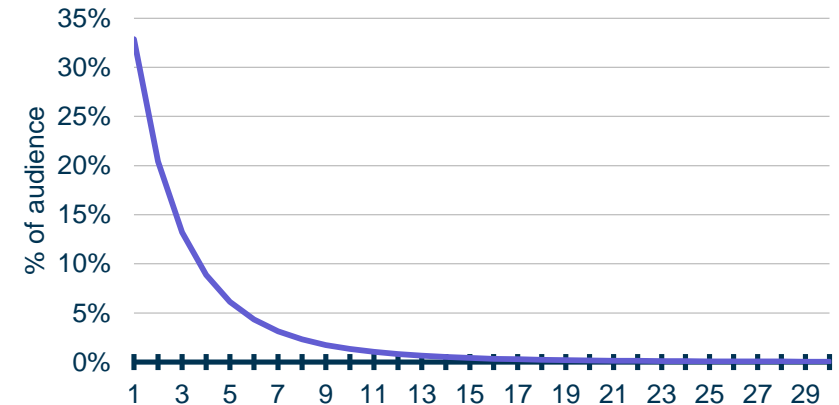

## Some of the services currently provided over fixed networks in Portugal might not be offered, or offered differently, over a NGN/IP network

- Some of the services currently provided by the Portuguese fixed operators are the result of the characteristics of traditional TDM networks and of regulation (e.g. local, single-tandem and double-tandem calls)
- The model assumes that the core services provided over the NGN/IP are based on existing services, though there might be some differences in the portfolio of services provided by NGN/IP operators compared to traditional operator-provided services. For example:
  - the existing local incoming call service will not be provided over the modelled NGN as the points of interconnection are located at the core level instead of at the regional level
  - the existing local and regional on-net service will also be provided by the same service over the modelled NGN network as the first point of traffic routing is located at the aggregation layer

High-level flow of a local on-net call

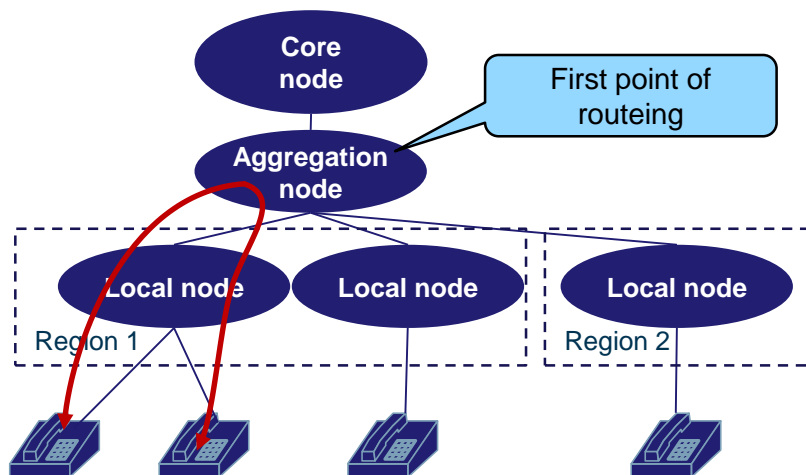

High-level flow of a regional on-net call

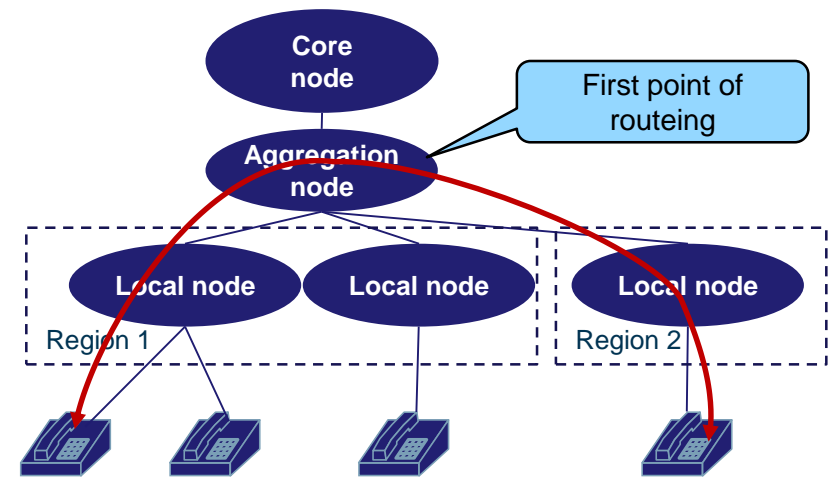

In an NGN, both local and regional on-net calls use the same network resources

## The traffic occurring in the busy hour is converted into network services traffic

### List of network services modelled

Service	Service
Regional on-net calls (retail)	National intra-node IP/E-VPN circuits
National intra-node on-net calls (retail)	National multi-node IP/E-VPN circuits
National multi-node on-net calls (retail)	Broadband (direct access subscribers)
Non-geographical on-net calls (retail)	Broadband (indirect access subscribers)
National intra-node outgoing calls (retail)	TV – Access
National multi-node outgoing calls (retail)	TV – L1 Aggregation
National intra-node incoming calls (wholesale)	TV (linear broadcast) – L2 Aggregation
National multi-node incoming calls (wholesale)	TV (VoD)
Incoming calls to non-geographical numbers	OTT services
National intra-node outgoing calls (wholesale)	Subscribers lines
National multi-node outgoing calls (wholesale)	Interconnection services
National intra-node outgoing calls to non-geographic numbers (wholesale)	
National multi-node outgoing calls to non-geographic numbers (wholesale)	
National intra-node transit calls (wholesale)	
National multi-node transit calls (wholesale)	

Voice services

Data services

TV and OTT services

Other services

## Network services traffic is derived from the market services

### Allocation of on-net market traffic to network services traffic

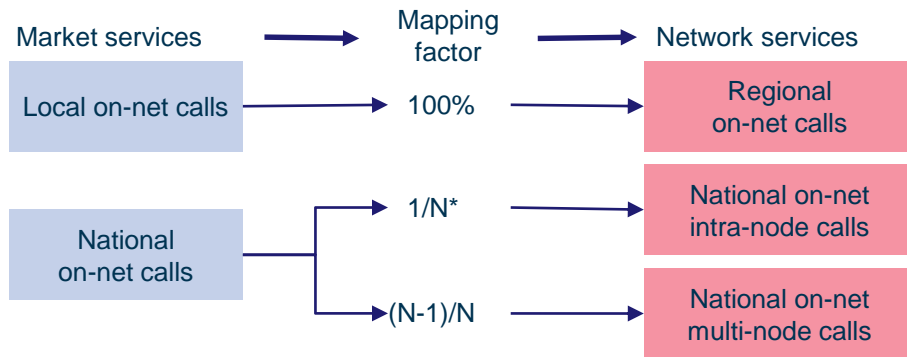

### Allocation of incoming market traffic to network services traffic

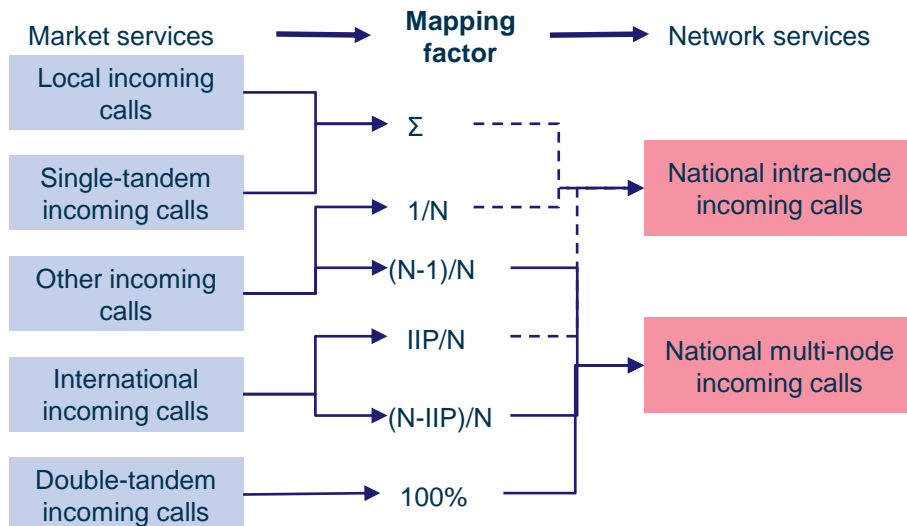

- **On-net traffic** is divided into one of the following three categories:

- *local on-net*: voice calls between two retail subscribers of the modelled operator located within the same regional node
- *national on-net intra-node calls*: voice calls between two retail subscribers of the modelled operator that are not located within the same regional node, but within the same national core node
- *national on-net multi-node calls*: voice calls between two retail subscribers of the modelled operator that are not located within the same national core node

- **Wholesale incoming traffic** is divided into one of the following two categories:

- *national intra-node incoming calls*: voice calls received from another international (mobile or fixed) operator and terminated on a retail subscriber of the modelled operator, after transiting on one of its national core nodes
- *national multi-node incoming calls*: voice calls received from another international (mobile or fixed) operator and terminated on a retail subscriber of the modelled operator, after transiting on two of its national core nodes

- The traffic from the **remaining network services** is derived using a similar approach

## A routing matrix converts network traffic into network loading

The routing matrix defines the load by service on each asset group

Routing factors for voice services

Network services	Access	Transmission aggregation-core nodes	Transmission core-core nodes	L1 Aggregation switching	L2 Aggregation switching	Access SBC	IP edge routing	Core routing	Core switching	Interconnection (incl. SBC/TGW)
Regional on-net calls	2	-	-	2	2	1	1	-	-	-
National intra-node on-net calls	2	2	-	2	2	2	2	1	-	-
National multi-node on-net calls	2	2	1	2	2	2	2	2	-	-
Non-geographical on-net calls	2	2	1	2	2	2	2	2	1	-
National intra-node outgoing calls	1	1	-	1	1	1	1	1	1	1
National multi-node outgoing calls	1	1	1	1	1	1	1	2	1	1
National intra-node incoming calls	1	1	-	1	1	1	1	1	1	1
National multi-node incoming calls	1	1	1	1	1	1	1	2	1	1
Incoming calls to non-geographical numbers	-	-	-	-	-	-	-	-	1	1
National intra-node outgoing calls (wholesale)	1	1	-	1	1	1	1	1	1	1
National multi-node outgoing calls (wholesale)	1	1	1	1	1	1	1	2	1	1
National intra-node outgoing calls to non-geographic numbers (wholesale)	1	1	-	1	1	1	1	1	1	1
National multi-node outgoing calls to non-geographic numbers (wholesale)	1	1	1	1	1	1	1	2	1	1
National intra-node transit calls	-	-	-	-	-	-	-	1	2	2
National multi-node transit calls	-	-	1	-	-	-	-	2	2	2

For example, national intra-node outgoing calls are routed via one core router ...

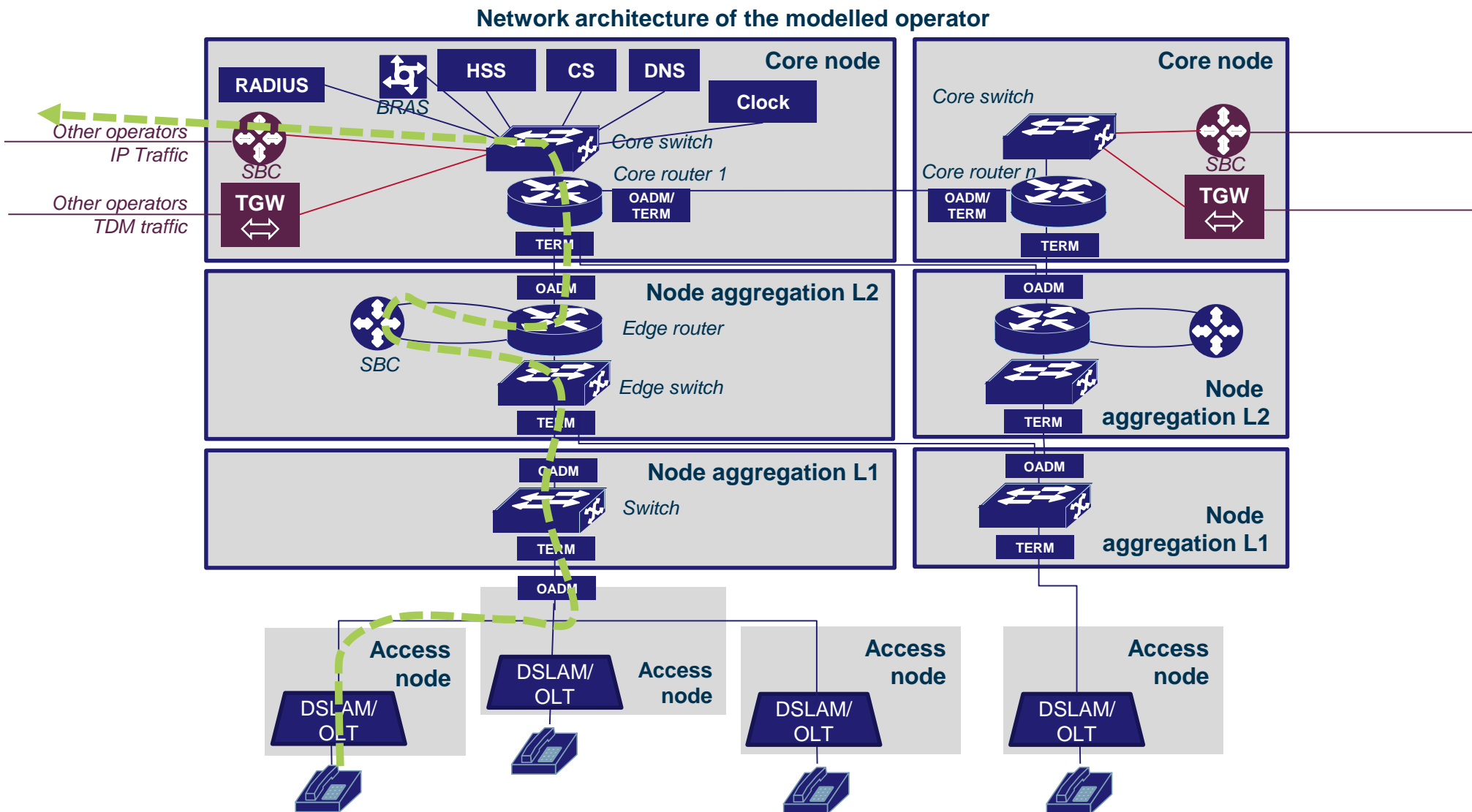

## ... while multi-node outgoing calls use two core routers ...

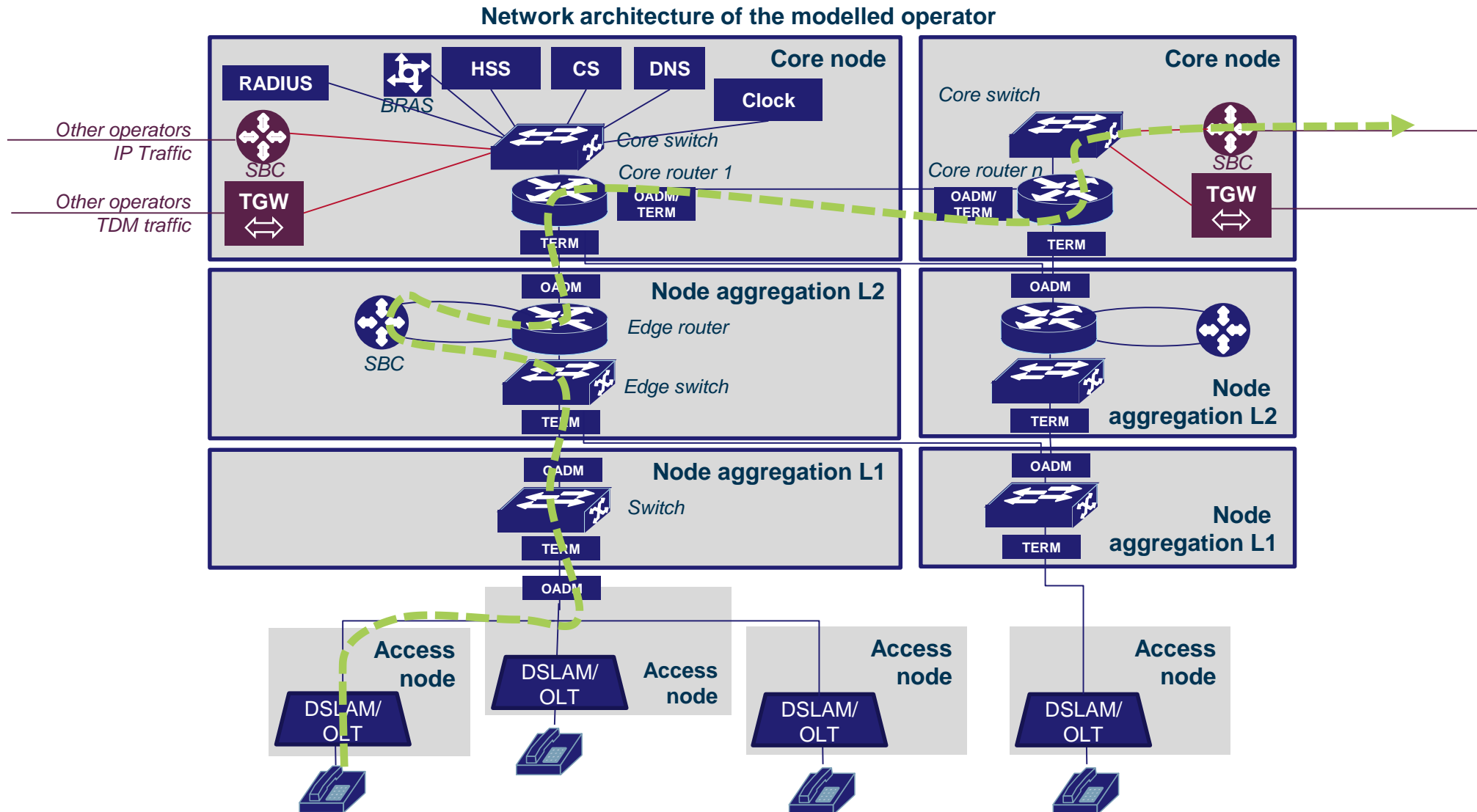



## ... as defined in the routing matrix

Routing factors for voice services

Network services	Access	Transmission aggregation-core nodes	Transmissi on core-core nodes	L1 Aggregation switching	L2 Aggregation switching	Access SBC	IP edge routing	Core routing	Core switching	Interconnec tion (incl. SBC/TGW)
Regional on-net calls	2	-	-	2	2	1	1	-	-	-
National intra-node on-net calls	2	2	-	2	2	2	2	1	-	-
National multi-node on-net calls	2	2	1	2	2	2	2	2	-	-
Non-geographical on-net calls	2	2	1	2	2	2	2	2	1	-
National intra-node outgoing calls	1	1	-	1	1	1	1	1	1	1
National multi-node outgoing calls	1	1	1	1	1	1	1	2	1	1
National intra-node incoming calls	1	1	0	1	1	1	1	1	1	1
National multi-node incoming calls	1	1	1	1	1	1	1	2	1	1
Incoming calls to non-geographic numbers	-	-	-	-	-	-	-	-	1	1
National intra-node outgoing calls (wholesale)	1	1	-	1	1	1	1	1	1	1
National multi-node outgoing calls (wholesale)	1	1	1	1	1	1	1	2	1	1
National intra-node outgoing calls to non-geographic numbers (wholesale)	1	1	-	1	1	1	1	1	1	1
National multi-node outgoing calls to non-geographic numbers (wholesale)	1	1	1	1	1	1	1	2	1	1
National intra-node transit calls	-	-	-	-	-	-	-	1	2	2
National multi-node transit calls	-	-	1	-	-	-	-	2	2	2

Introduction

Overview of the model

Market module

**Network design module**

Service costing module

Model results

Annexes

Overview of the network architecture

Demand conversion

**Physical design of the network**

Access network

Aggregation network

Core network

## The number of nodes of the modelled operator is consistent with the configuration of a fixed operator with national coverage

- The core network of the modelled operator comprises four main levels:
  - **access layer:** is responsible for aggregating the traffic received from the end subscribers and for transmitting it to the core network, and *vice versa*
    - nodes are connected using either trees or rings
      - number of access nodes: 1669
      - we have used MEO's network to determine the number of nodes in the access layer
  - **aggregation layer:** responsible for aggregating the traffic from the access nodes and for distributing it to the core nodes
    - each aggregation node is connected to two core nodes
    - the aggregation layer of the modelled operator is split into two layers: L1 and L2
      - L1 aggregation nodes: 166
      - L2 aggregation nodes: 25
  - **core layer:** responsible for distributing the traffic at the national level
    - the modelled operator has 5 core nodes
- We have utilised the number of nodes of the fixed operators to determine the number of nodes on the aggregation and core layers:
  - our estimates are consistent with the configuration of a fixed operator with national coverage

### Nodes of the modelled operator per network layer

**GRAPH REMOVED TO  
PROTECT CONFIDENTIAL  
OPERATOR INFORMATION**

# An offline geographical analysis associates the nodes to their parent ones and creates the rings to connect them

## Calculation of the physical architecture of the network

- The physical design of the network is executed through a multi-step approach that:
  1. first relates the nodes of the different network levels to their parent nodes
  2. then calculates the infrastructure required to connect them physically
- In the first step, a geographical analysis is performed to associate the nodes of a given network level to their parent nodes in the upper network level:
  - L1 and L2 nodes are associated to two parent nodes in order to ensure redundancy
  - Madeira and Azores are considered independent networks and are only connected to mainland Portugal through a submarine cable connecting their L2 nodes to Lisbon's core network nodes; submarine cables have been explicitly modelled
- In a second step, the physical network is calculated based on associations between nodes previously calculated:
  - the rings are created using the TSP (Travelling Salesman Problem) algorithm, which provides the optimal rings topologies covering all nodes considered in an association

## Calculation of the distance between points

- Different methodologies can be used to calculate the distance between two points, but they rarely represent reality

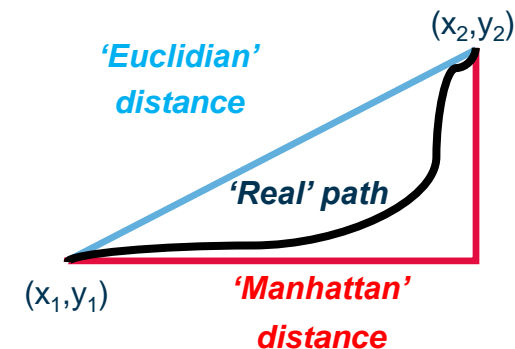

- The 'Manhattan' distance tends to overestimate the actual distance, while the 'Euclidian' one tends to underestimate it
- In our model, we have calculated distances using the Euclidian distance:
  - we have added a mark-up to the distances previously calculated in order to consider the inefficiencies resulting from geographical constraints (e.g. geographical accidents such as mountains or rivers, etc.)
  - this mark-up has been calculated by comparing the straight distances and real distances of a sample of over 1000 rings and trees resulting from the model

## The design of the network linking the access nodes includes both rings and trees

---

- The access layer comprises of nodes that are connected using in a ring or a tree structure:
  - 170 rings connect the access nodes to the L1 nodes
  - depending on the number of lines per local exchange, each node has been assigned to a ring (nodes with a larger number of lines) or to a tree (conversely)
- Each local exchange is connected to the closest L1 aggregation node that belongs to the same geotype:
  - the access network of the modelled operator is not redundant
- The output of the analysis is c. 21 800km of fibre and c. 19 200km of ducts in the access layer

## The transmission network in the aggregation and core nodes is structured into rings that provide full redundancy except in the islands

- Rings are deployed to connect the L1, L2 and core nodes:
  - 28 rings connect the L1 nodes to the L2 nodes
  - 7 rings connect the L2 nodes to the core nodes
  - two core rings connect the core nodes between them in order to provide redundancy
- Each node is connected to the two closest parent nodes in order to ensure redundancy in the network:
  - exceptions are allowed in the islands
    - the L1 nodes in Madeira are connected to the only L2 node in the island (to avoid several submarine links)
    - all the L2 nodes in the Azores and Madeira islands are connected to the core nodes in mainland Portugal through submarine cables modelled *ad hoc*

### Physical design of the L1 and L2 aggregation layers

**GRAPH REMOVED TO PROTECT CONFIDENTIAL OPERATOR INFORMATION**

### Length of fibre cables and ducts by network level (km)

Network level	Fibre	Ducts
L1 aggregation	5,924	5,924
L2 aggregation	2,172	2,157
Core	733	715

Introduction

Overview of the model

Market module

**Network design module**

Service costing module

Model results

Annexes

Overview of the network architecture

Demand conversion

Physical design of the network

**Access network**

Aggregation network

Core network

The access layer is responsible for multiplexing the traffic received from the subscribers and transmitting it to the core network, and *vice versa*

High-level diagram of the access network

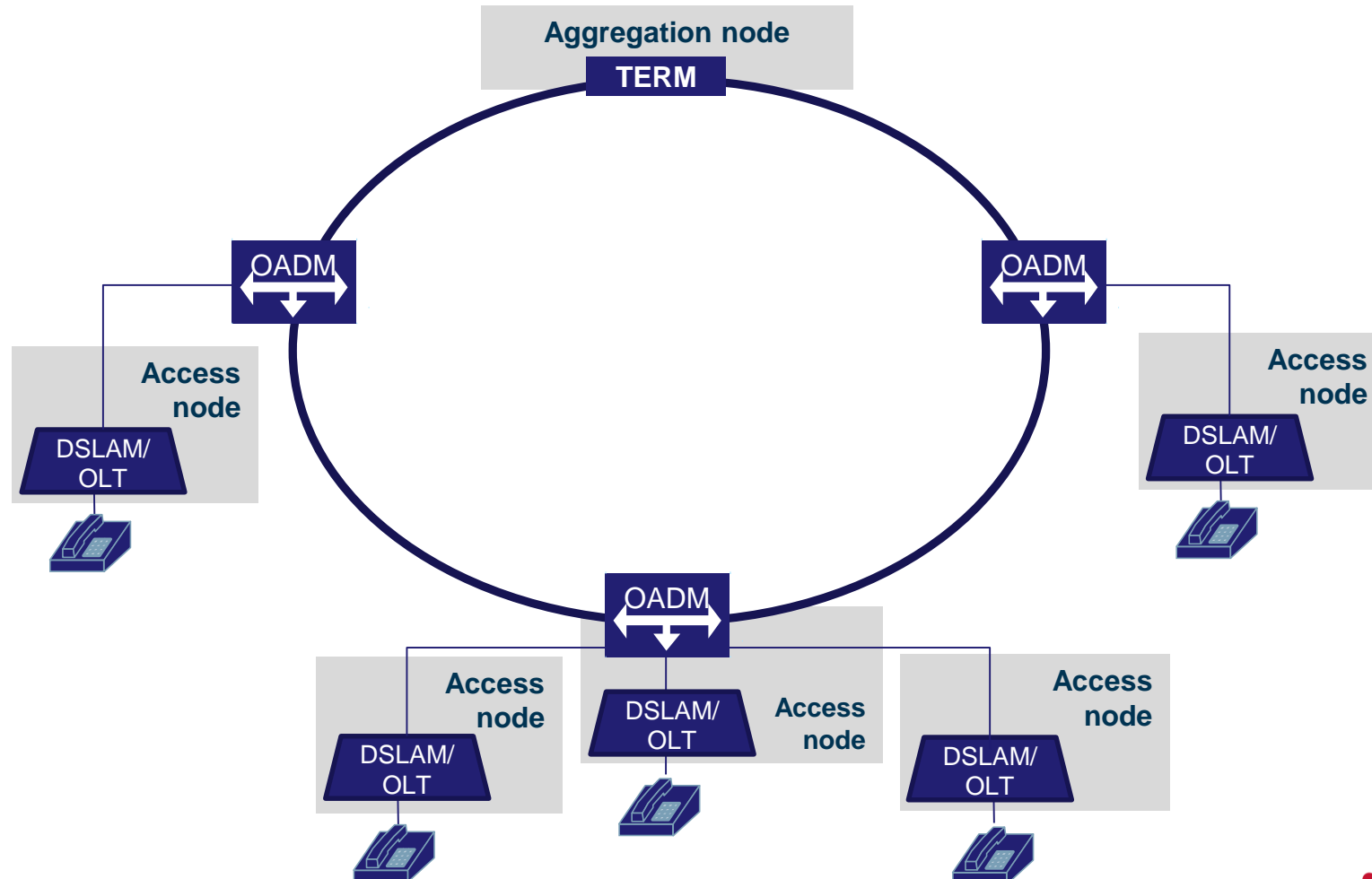



## Dimensioning of the DSLAMs and uplink ports

### High-level flow of calculations to dimension the number of DSLAMs

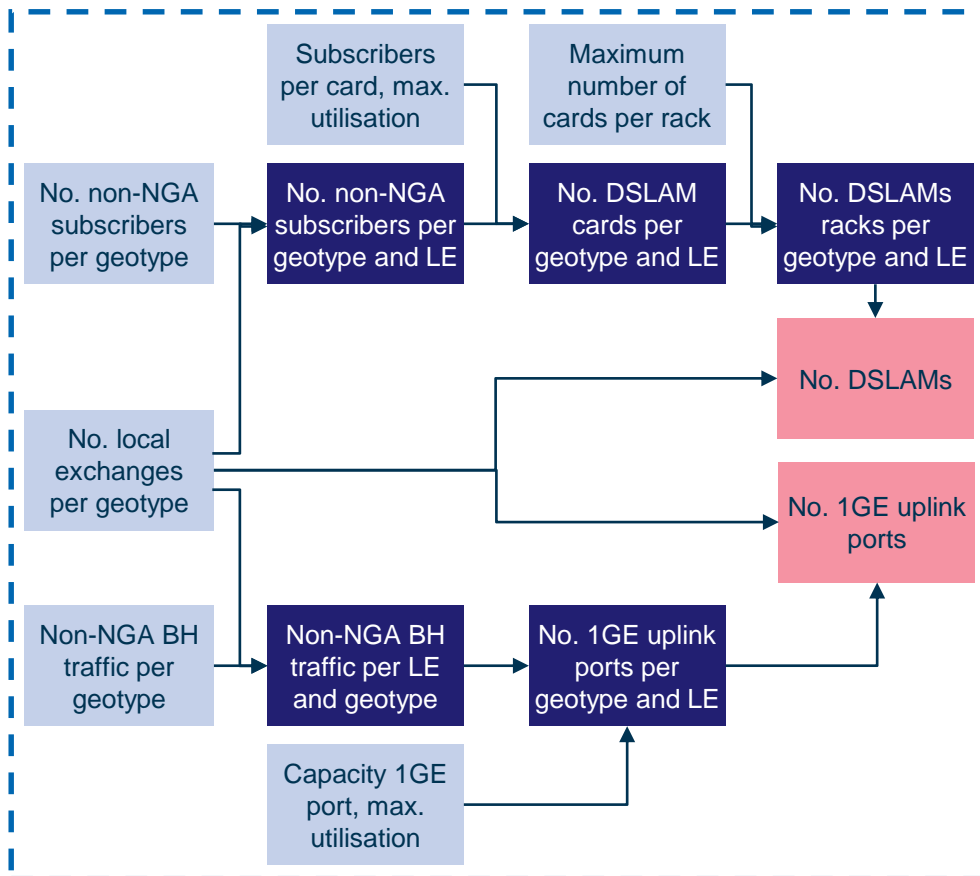

KEY:  Input  Calculation  Final/intermediate outputs

#### Methodology to estimate the number of DSLAMs:

- DSLAMs multiplex the traffic from non-NGA subscribers onto the core network
- based on the number of non-NGA subscribers and the number of local exchanges, the model calculates the average number of non-NGA subscribers per local exchange and geotype
- the number of cards is derived from both the average number of non-NGA subscribers per local exchange and the available ports per card
- the number of racks is driven by the number of cards per local exchange and geotype

#### Methodology to estimate the number of uplink ports:

- the number of 1GE uplink ports is determined by
  - the number of DSLAMs deployed
  - the number of ports required to carry the traffic in the busy hour from non-NGA subscribers (capacity-driven ports)

Parameter	Value	Source
Ports per DSLAM line card	48	AM* estimates, operator data
Line cards per shelf	10	AM estimates, operator data
Shelves per rack	1	AM estimates, operator data
DSLAM subs. utilisation factor	N/A*	AM estimates, operator data
Uplink ports utilisation factor	80%	AM estimates, operator data

\*Analysys Mason

## An off-line geographical analysis is used to calculate the number of *parent local exchanges* per geotype

- Fibre access technologies such as GPON and point-to-point (PTP) support local loops with a length of 20km, while in traditional copper loops length is limited to only a few kilometres:
  - fibre subscribers are usually connected to *parent local exchanges* instead of to the smaller local exchanges used to connect copper subscribers
    - *parent local exchanges* are exchanges that cover areas previously covered by smaller local exchanges located within the same area of influence
    - the OLTs are located in the *parent local exchanges*
- We have conducted an off-line geographical analysis to estimate the maximum number of *parent local exchanges* per geotype:
  - the model considers that two local exchanges are within the same area of influence if the distance between them is less than 15km
    - there is a margin of 5km to guarantee that all the copper subscribers connected to the smaller local exchange are within a range of up to 20km from the *parent local exchange*

Number of local exchanges and parent local exchanges per geotype

<i>Geotype</i>	<i>No. local exchanges</i>	<i>No. parent local exchanges</i>	<i>Source</i>
Geotype 1	1153	318	Analysys Mason estimates based on ANACOM's, INE's data
Geotype 2	219	67	Analysys Mason estimates based on ANACOM's, INE's data
Geotype 3	172	61	Analysys Mason estimates based on ANACOM's, INE's data
Geotype 4	125	67	Analysys Mason estimates based on ANACOM's, INE's data
<b>Total</b>	<b>1669</b>	<b>513</b>	<b>Analysys Mason estimates based on ANACOM's, INE's data</b>

## Dimensioning of the OLTs and uplink ports

### High-level flow of calculations to dimension the number of OLTs

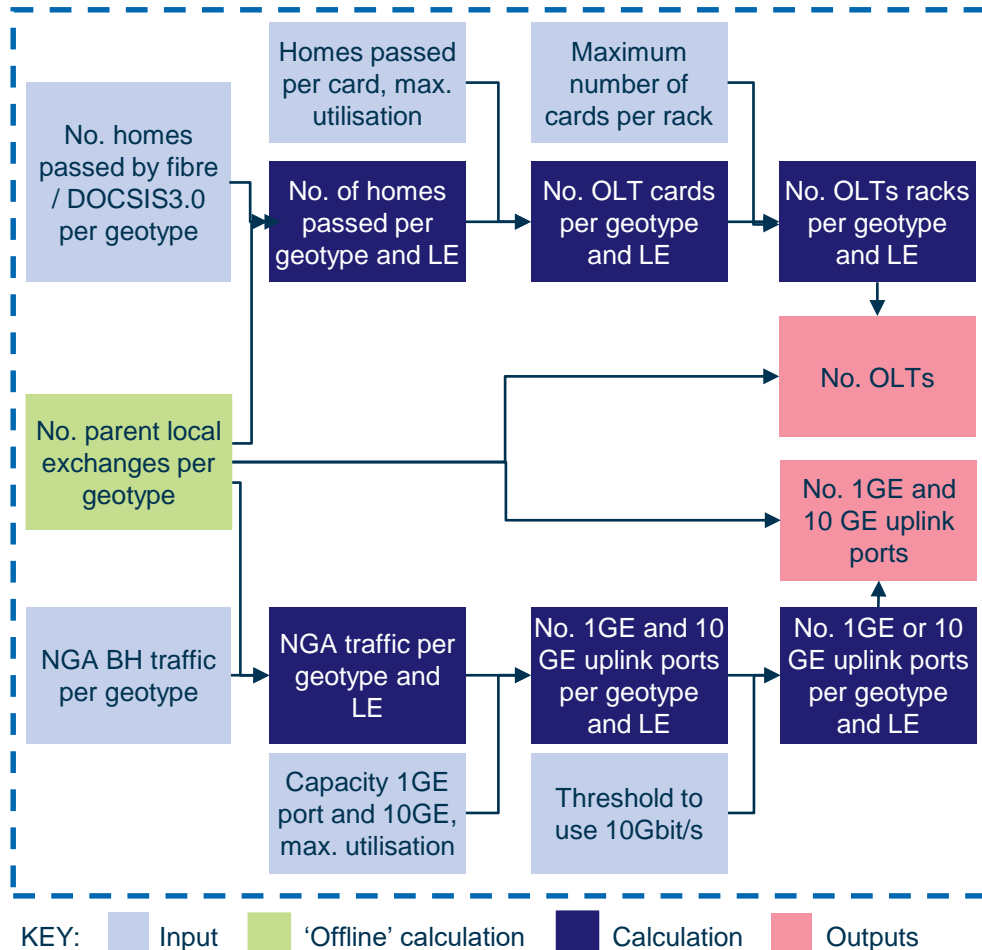

2010987-115

**\* DATA REMOVED TO PROTECT  
CONFIDENTIAL OPERATOR INFORMATION**

### Methodology to estimate the number of OLTs:

- OLTs multiplex the traffic from NGA subscribers onto the core network
- based on the annual number of homes passed by NGA technologies (i.e. DOCSIS 3.0 and fibre) and the number of parent local exchanges per geotype, the model calculates the total number of OLTs required

### Methodology to estimate the number of uplink ports:

- OLTs can support uplink ports of either 1GE or 10GE
  - the model estimates whether it is more efficient to use 1GE or 10GE ports, based on a threshold defined by the costs associated to both configurations

### OLT's technical parameters

Parameter	Value	Source
Subscribers per GPON port	64	Analysys Mason estimates, operator data
Ports per OLT card	10	Analysys Mason estimates, operator data
OLT cards per rack	16	Analysys Mason estimates, operator data
Homes passed utilisation factor	100%	Analysys Mason estimates
Uplink ports utilisation factor	N/A*	Analysys Mason estimates, operator data
Threshold to use 10Gbit/s	1	Analysys Mason estimates

## Dimensioning of the access rings

### High-level flow of calculations to dimension the access rings

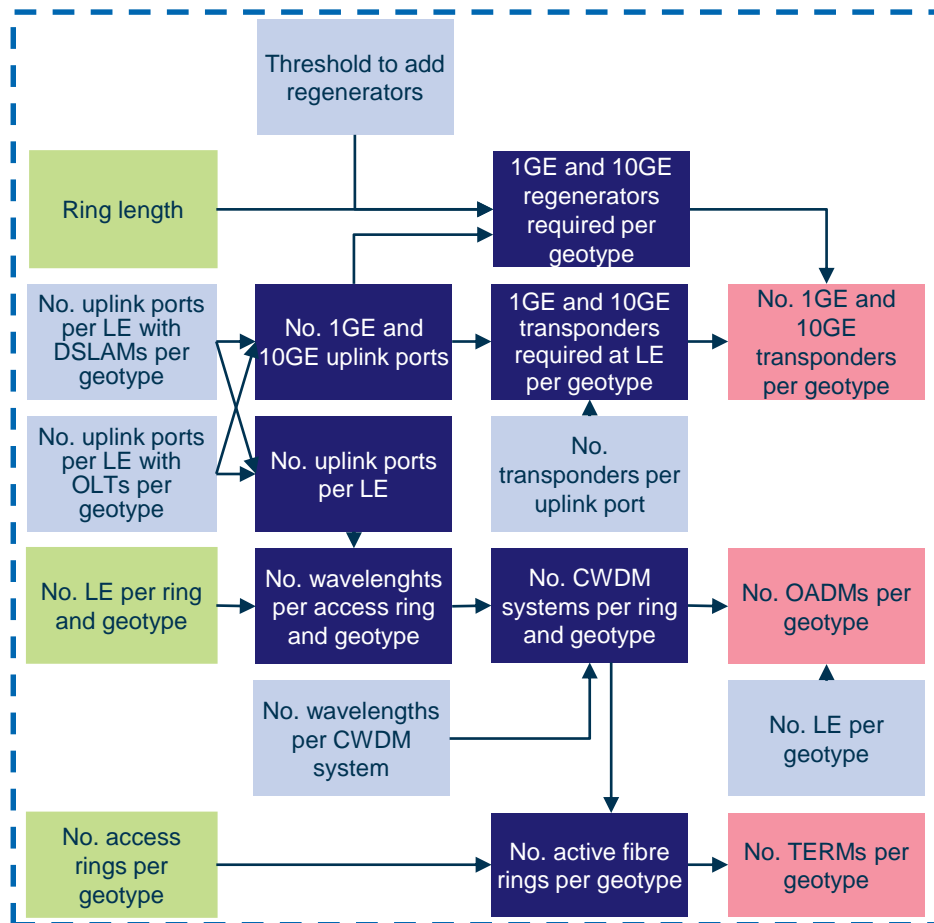

KEY:   Input   'Offline' calculation   Calculation   Outputs

- Traffic at this layer is carried over CWDM rings<sup>(\*)</sup>
- **Methodology to estimate the number of transponders:**
  - transponders perform an optical-electrical-optical (OEO) conversion. They are used to
    - adapt an optical signal to a specific wavelength
    - regenerate the optical signal
  - two transponders per uplink port are provisioned in order to transmit the signal to both sides of the ring
  - the model assumes that a regenerator needs to be deployed every 70km to maintain signal strength
- **Methodology to estimate the number of OADMs and TERMS:**
  - OADMs and TERMS are used to add and drop wavelengths into a wave division multiplexing (WDM) system
  - the number of OADMs is driven by both the number of CWDM systems per ring and the number of rings and nodes
    - a CWDM system can be used with up to 16 channels (wavelengths)
    - in the case where a new CWDM system is required, an additional fibre pair is used in the ring
  - the number of TERMS is equal to the number of active fibre pairs

<sup>(\*)</sup> The model also allows to test the impact of using either DWDM or NG-SDH at the access level. In the case of NG-SDH, the model calculates the number of STM-4, STM-16 and/or STM-64 ADMs required to transport the signal to the core layer

Introduction

Overview of the model

Market module

**Network design module**

Service costing module

Model results

Annexes

Overview of the network architecture

Demand conversion

Physical design of the network

Access network

▶ **Aggregation network**

Core network

## The aggregation layer consists of two independent layers, improving the resilience of the network of the modelled operator

High-level diagram of the aggregation network

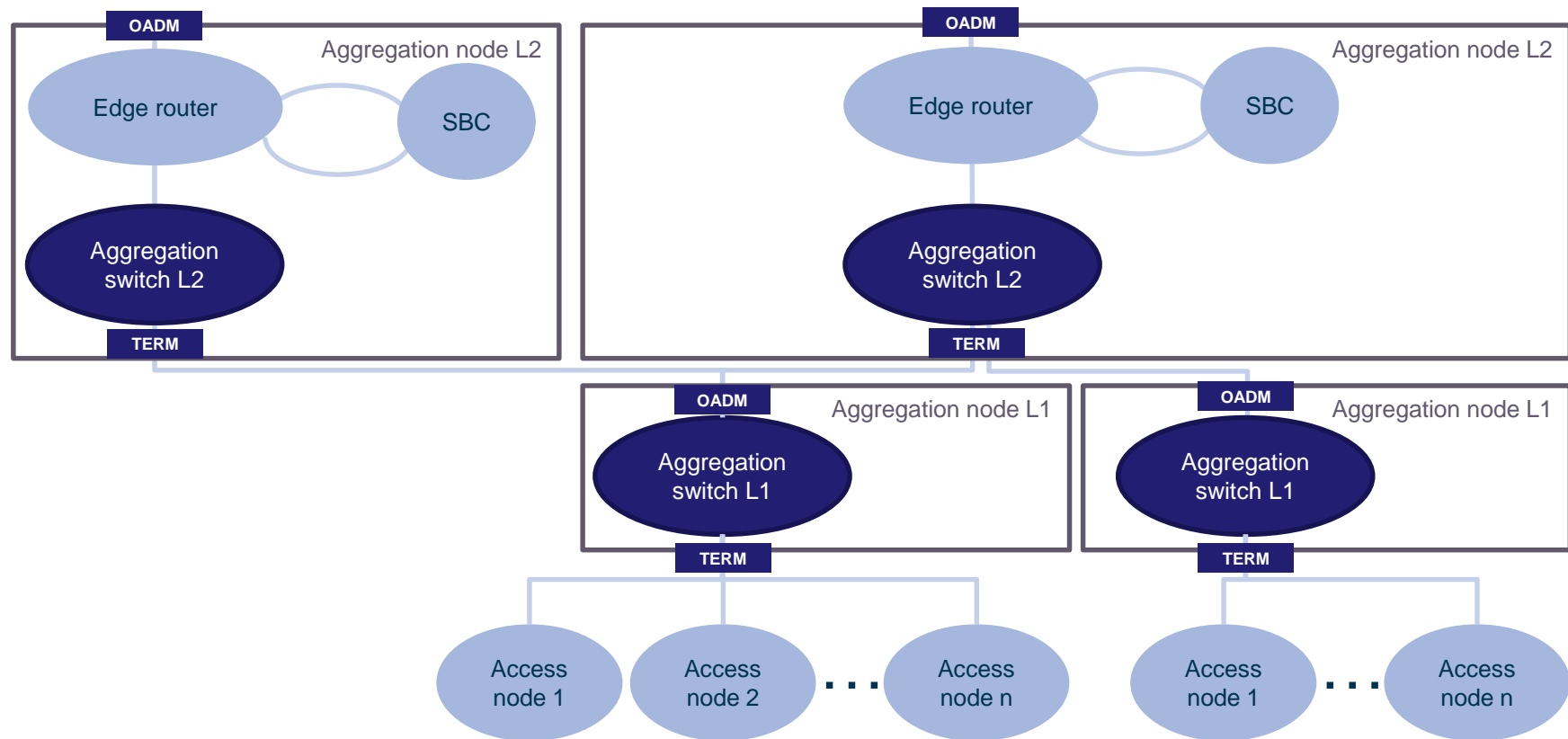

## L1 nodes aggregate the traffic from nodes located in the same geotype; while L2 nodes can aggregate the traffic from nodes located in different geotypes

High-level diagram of the access and aggregation networks

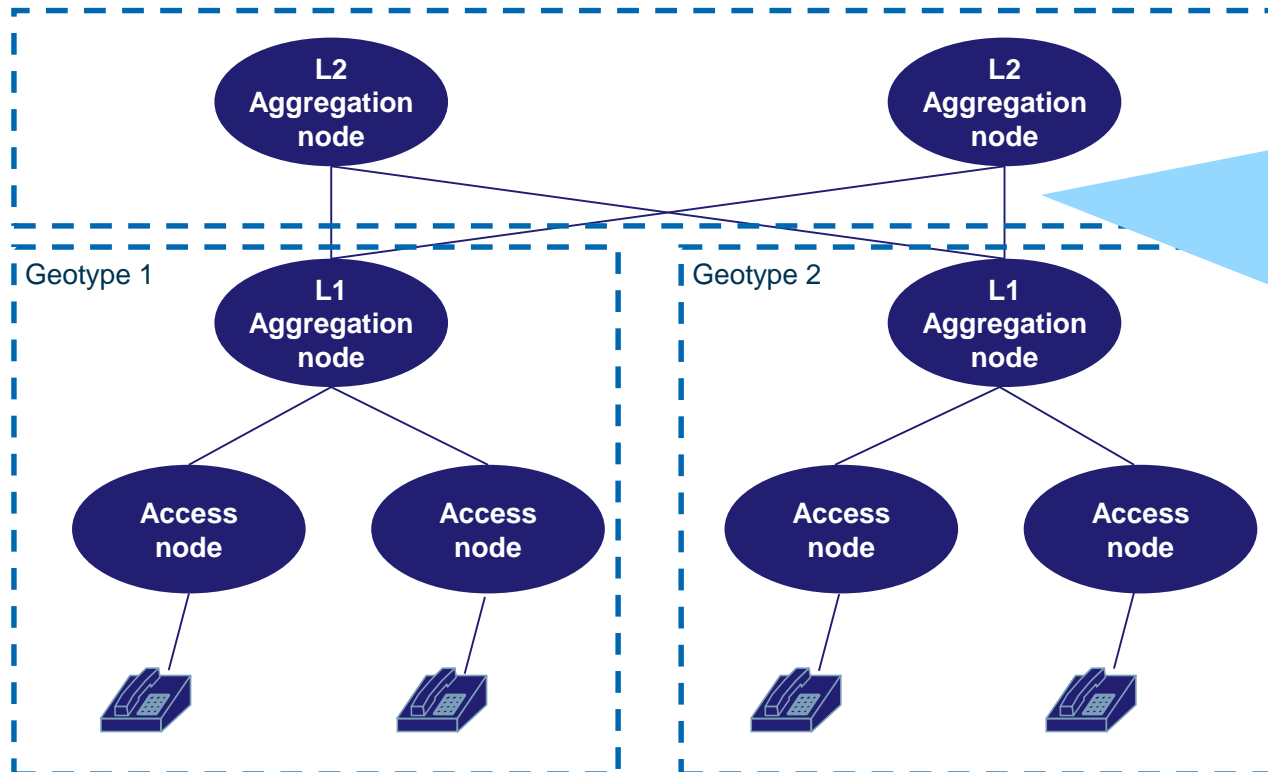

- Traffic from the access nodes is always aggregated in a L1 node located in the same geotype. In contrast, L2 nodes can aggregate the traffic from nodes located in different geotypes.
- Consequently, the L1 switches are dimensioned using geotypes (i.e. average number of L1 switches required to carry the traffic on each of the geotypes), while the L2 switches are dimensioned at a national level (i.e. average number of L2 switches required to carry the traffic in the busy hour in Portugal)

## Dimensioning of L1 Ethernet switches

### High-level flow of calculations to dimension the L1 Ethernet switches

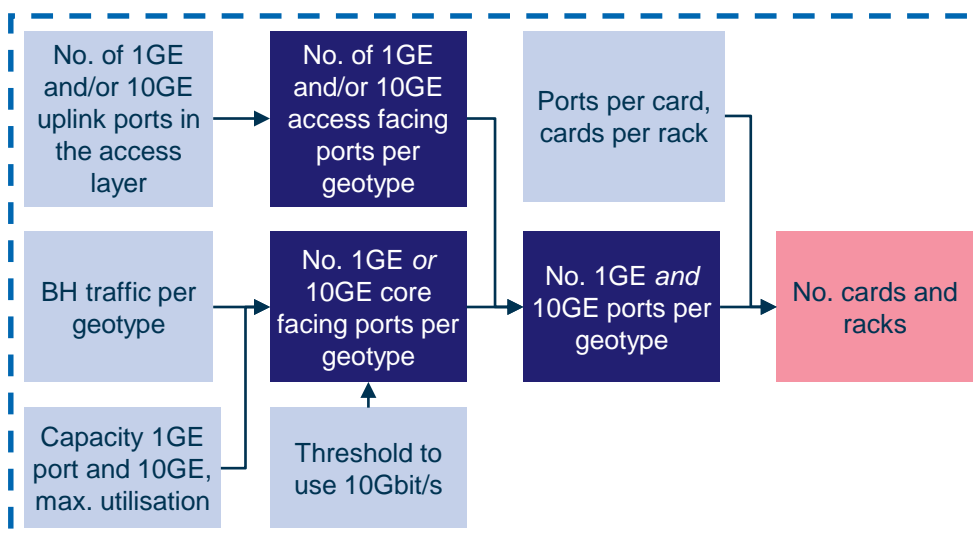

KEY

Input

Calculation

Final/intermediate outputs

- Ethernet switches are used to aggregate traffic. The number of racks and cards is driven by the number of ports, which is in turn derived from:
  - *access-facing ports*: uplink ports from the access nodes
  - *core-facing ports*: the number of core-facing ports is determined by
    - the number of switches deployed: each switch will require a minimum of one core-facing port
    - the number of ports required to carry the traffic occurring in the busy hour (capacity-driven ports)
    - redundancy: in order to improve the redundancy of the network the number of core-facing ports is multiplied by two

### Technical parameters for the dimensioning of Ethernet switches

Parameter	Value	Source
Ports per 1GE card	48	Analysys Mason estimate, operator data
Ports per 10GE card	12	Analysys Mason estimate, operator data
Cards per rack	6	Analysys Mason estimate, operator data
Uplink ports utilisation factor	N/A*	Analysys Mason estimate, operator data
Threshold to use 10Gbit/s	1	Analysys Mason estimate



## Dimensioning of access SBCs

### High-level flow of calculations to dimension the access SBCs

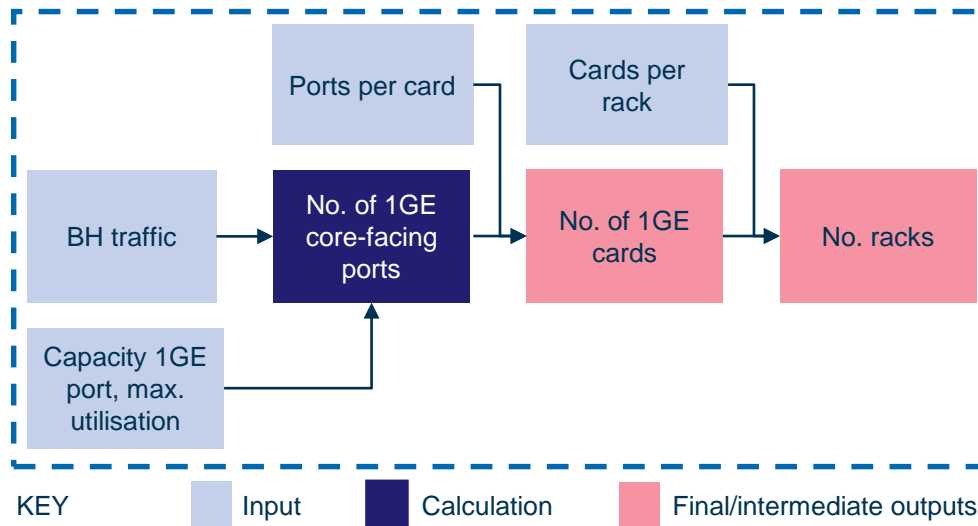

- The access SBC controls the bandwidth allocation per call or per session and provides security between the different network domains (e.g. network address translation, stopping denial of service attacks, etc.)
- The number of access SBC cards is driven by:
  - *minimum port deployment*: each SBC will require a minimum of 1GE port
  - busy-hour traffic requirements: the number of ports required to carry the traffic in the busy hour (capacity-driven ports)
  - in order to improve the redundancy of the network the number of ports is multiplied by two
- The number of racks is derived from both the total number of cards required and the available card slots per rack

### Technical parameters used in the dimensioning of access SBCs

Parameter	Value	Source
Ports per 1GE card	2	Analysys Mason estimate
Cards per rack	2	Analysys Mason estimate
Ports utilisation factor	N/A*	Analysys Mason estimate, operator data

## Dimensioning of edge routers

### High-level flow of calculations to dimension the edge routers

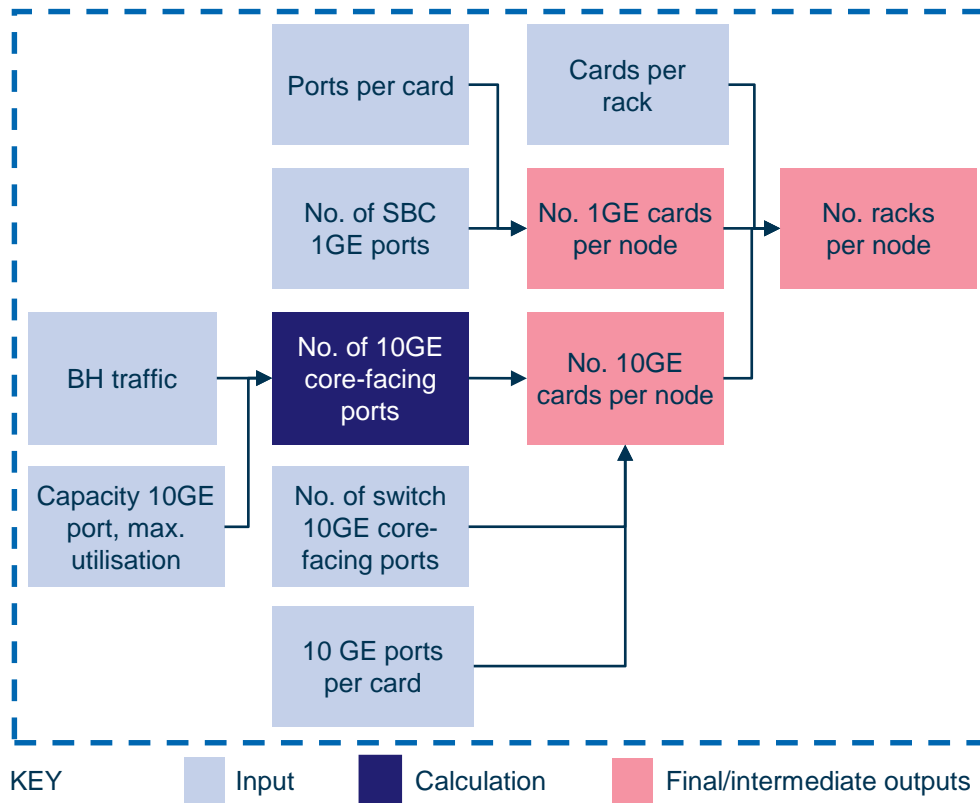

- Edge routers are used for routing the traffic from the access layer to the core nodes or to another DSLAM / OLT located within the same aggregation node, and *vice versa*:
  - edge routers are capable of transmitting local on-net calls to a receiver within the same area (without reaching the core layer)
- The model assumes that the edge routers can have two types of ports:
  - 1GE ports*: driven by the number of SBC ports
  - 10GE ports*: driven by both the number of core-facing ports in the L2 switch and the busy-hour traffic requirements. In order to improve the redundancy of the network the number of core-facing ports is multiplied by 2
- The number of ports determines the number of 1GE and 10GE cards, which in turn drives the total number of racks required

### Technical parameters used in the dimensioning of edge routers

Parameter	Value	Source
Ports per 1GE card	20	Analysys Mason estimate, operator data
Ports per 10GE card	2	Analysys Mason estimate, operator data
Cards per rack	12	Analysys Mason estimate, operator data
Uplink ports utilisation factor	N/A*	Analysys Mason estimate, operator data

## Dimensioning of aggregation rings

### High-level flow of calculations to dimension the aggregation rings

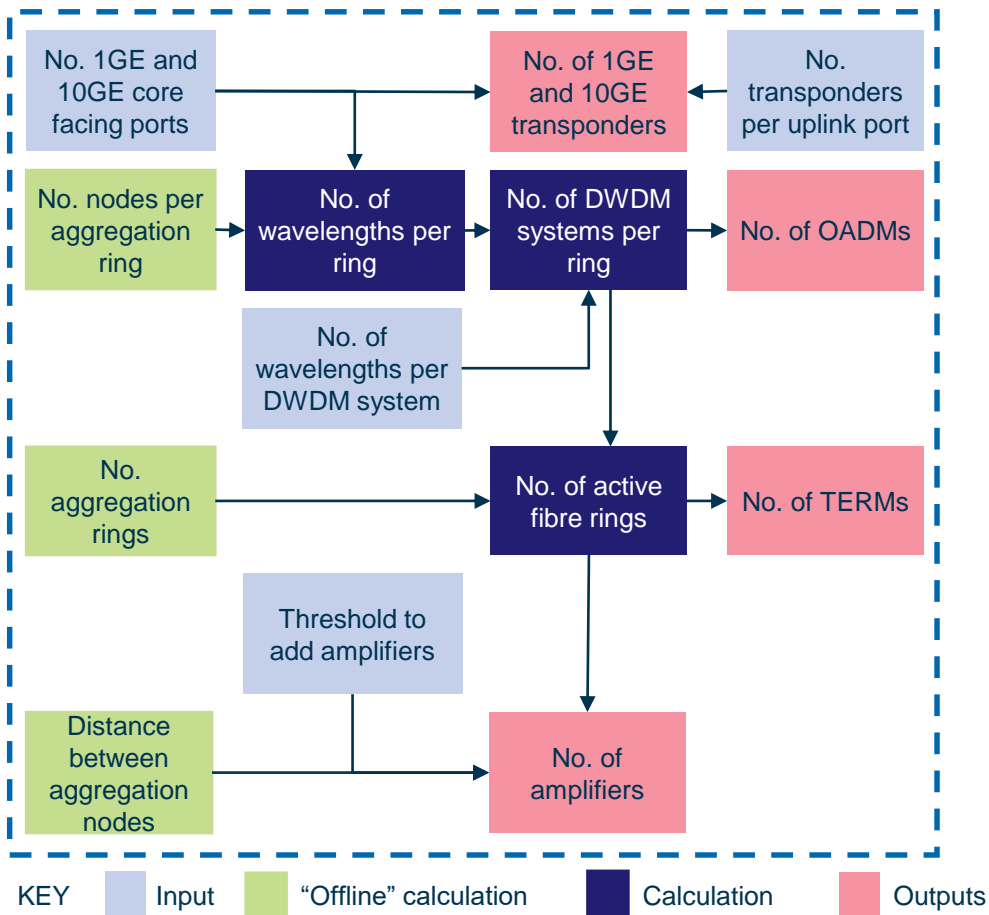

- Traffic at this layer is carried over DWDM rings<sup>(\*)</sup>
- **Methodology to estimate the number of transponders:**
  - transponders perform an OEO conversion
    - two transponders per uplink port are provisioned in order to transmit the signal to both sides of the ring
  - the model assumes that an optical amplifier needs to be deployed every 80km to maintain signal strength
- **Methodology to estimate the number of OADMs and TERMS:**
  - OADMs and TERMS are used to add and drop wavelengths into a WDM system
  - the number of OADMs is driven by both the number of DWDM systems per ring and the number of rings and nodes
    - a DWDM system can be used with up to 40 channels (wavelengths)<sup>(\*)</sup>
    - in the case where a new DWDM system is required, an additional fibre pair is used in the ring
  - the number of TERMS is equal to the number of active fibre pairs

Introduction

Overview of the model

Market module

**Network design module**

Service costing module

Model results

Annexes

Overview of the network architecture

Demand conversion

Physical design of the network

Access network

Aggregation network

▶ **Core network**

# The core layer manages and distributes the traffic nationwide and hosts the IMS equipment

High-level diagram of the core network

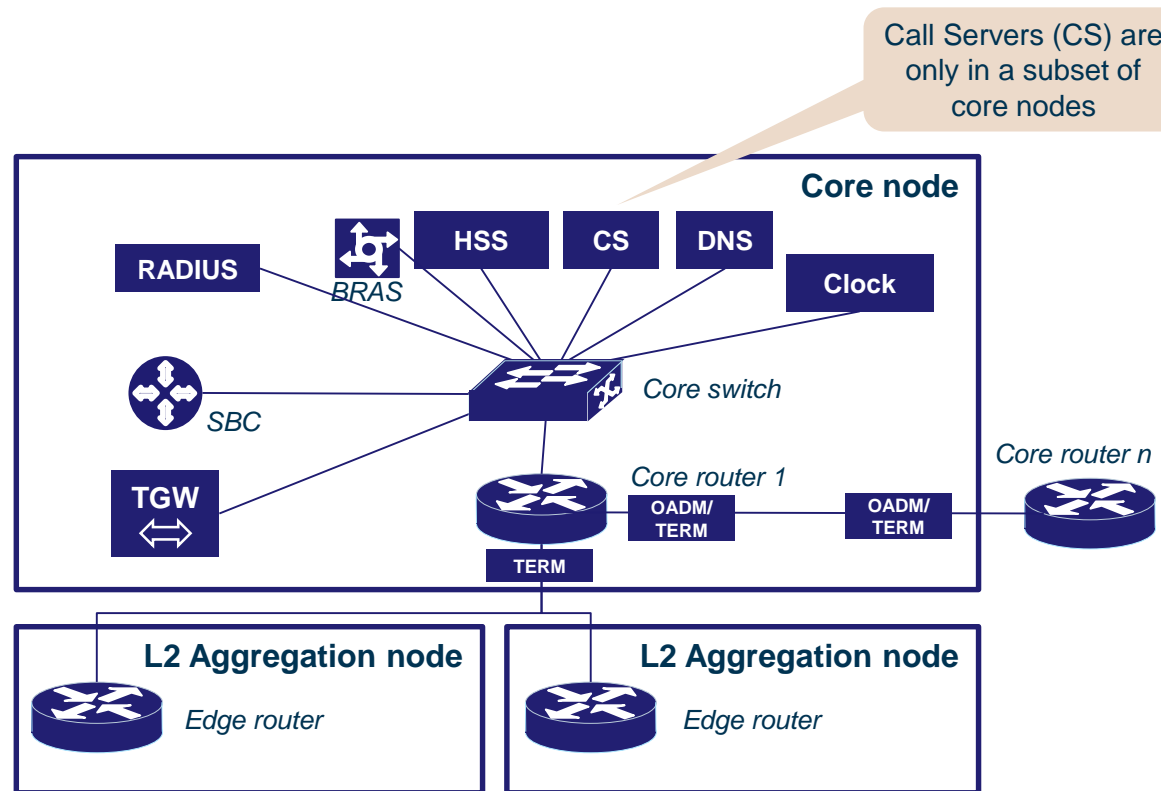

## Dimensioning of the core routers

### High-level flow of calculations to dimension the core routers

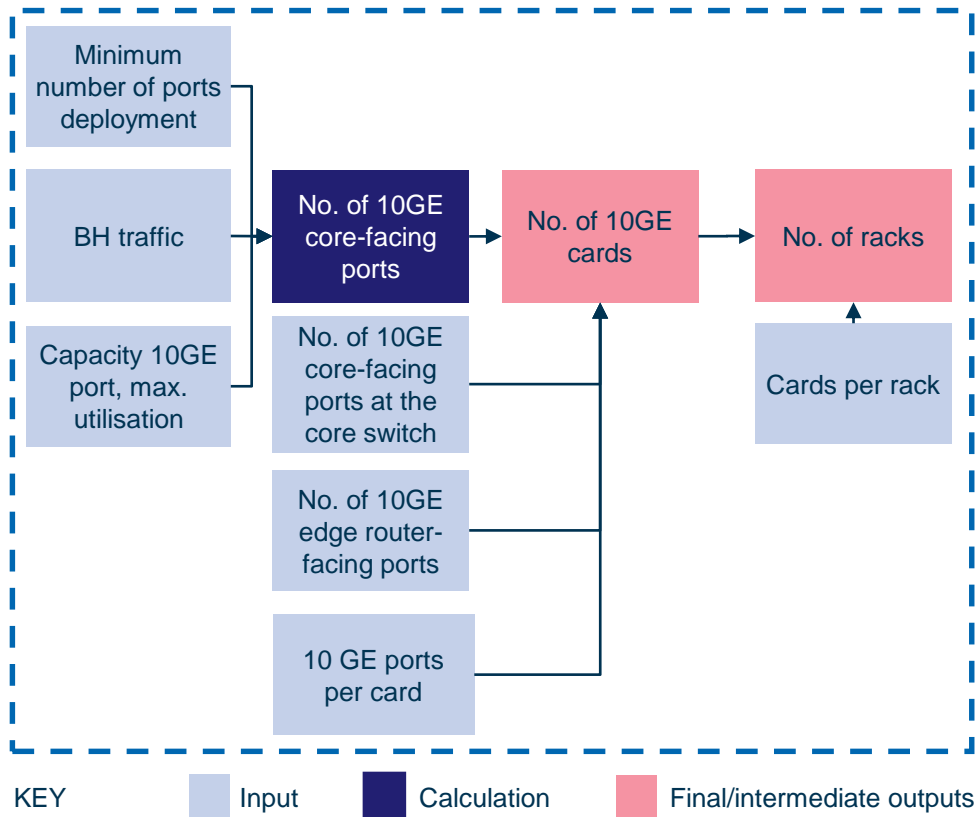

- Core routers are used for routing the traffic between aggregation and core nodes, and between core nodes
- The deployment of core routers is driven by:
  - the number of 10GE ports to other core routers, which is determined by
    - busy-hour traffic requirements at the core layer
    - minimum port deployment: we have modelled a fully meshed core layer (all core routers have at least two direct logical connections with other core routers). Therefore, the minimum number of ports to other core routers is equal to  $n-1$ ,  $n$  being the number of core nodes
  - the number of 10GE edge router-facing ports, which is equal to the number of 10GE core-facing ports at the edge routers of the L2 aggregation nodes
  - the number of 10GE core switch-facing ports, which is equal to the number of 10GE core-facing ports at the core switches

### Technical parameters used in the dimensioning of the core routers

Parameter	Value	Source
Ports per 10GE card	4	Analysys Mason, operator data
Cards per rack	8	Analysys Mason, operator data
Ports utilisation factor	N/A*	Analysys Mason, operator data

## Dimensioning of the core switches

### High-level flow of calculations to dimension the core switches

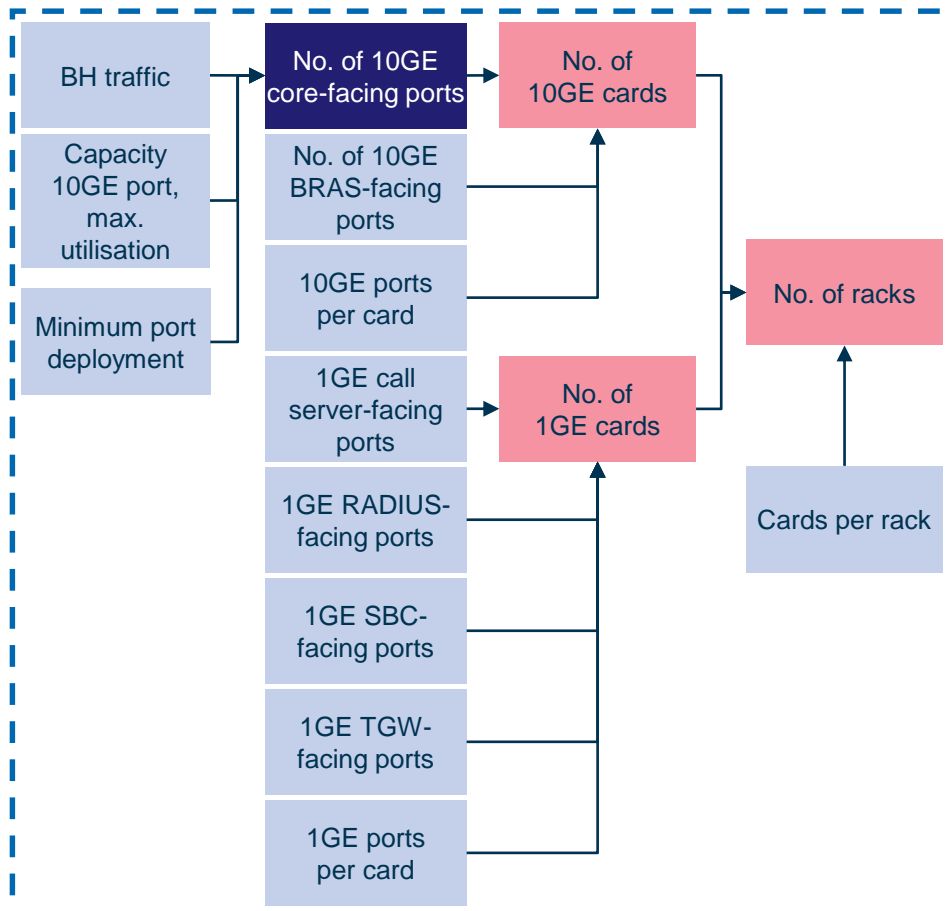

KEY

Input

Calculation

Final/intermediate outputs

- Core switches are used to connect the voice, data and interconnection platforms (e.g. TGW, SBC, BRAS, DNS, RADIUS and CS if present in that node) with the core network
- The model assumes that the core switches can have two types of ports:
  - 1GE ports*: driven by the core switch-facing ports at the
    - call server
    - RADIUS server
    - SBCs
    - TGWs
  - 10GE ports*: driven by
    - busy-hour traffic requirements: in order to improve the redundancy of the network the number of ports is multiplied by 2
    - core switch-facing ports at the BRAS

### Technical parameters used in the dimensioning of the core switches

Parameter	Value	Source
Ports per 1GE card	48	Analysys Mason, operator data
Ports per 10GE card	12	Analysys Mason, operator data
Cards per rack	6	Analysys Mason, operator data
Ports utilisation factor	N/A*	Analysys Mason, operator data

**\* DATA REMOVED TO PROTECT CONFIDENTIAL OPERATOR INFORMATION**

## Dimensioning of the SBCs for interconnection

### High-level flow of calculations to dimension the SBCs for interconnection

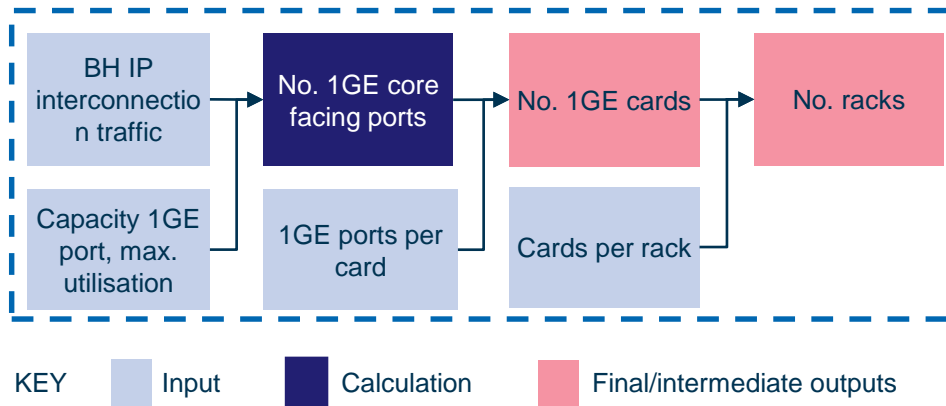

- SBCs monitor and managed the QoS of the IP interconnection traffic
- The SBCs in the model are driven by the IP interconnection traffic. Therefore, if all the interconnection traffic is TDM, no SBC for interconnection will be deployed

### Technical parameters used in the dimensioning of SBCs

Parameter	Value	Source
Ports per 10GE card	2	Analysys Mason estimate
Cards per rack	2	Analysys Mason estimate
Ports utilisation factor	N/A*	Analysys Mason, operator data



## Dimensioning of the TGWs

### High-level flow of calculations to dimension the TGWs

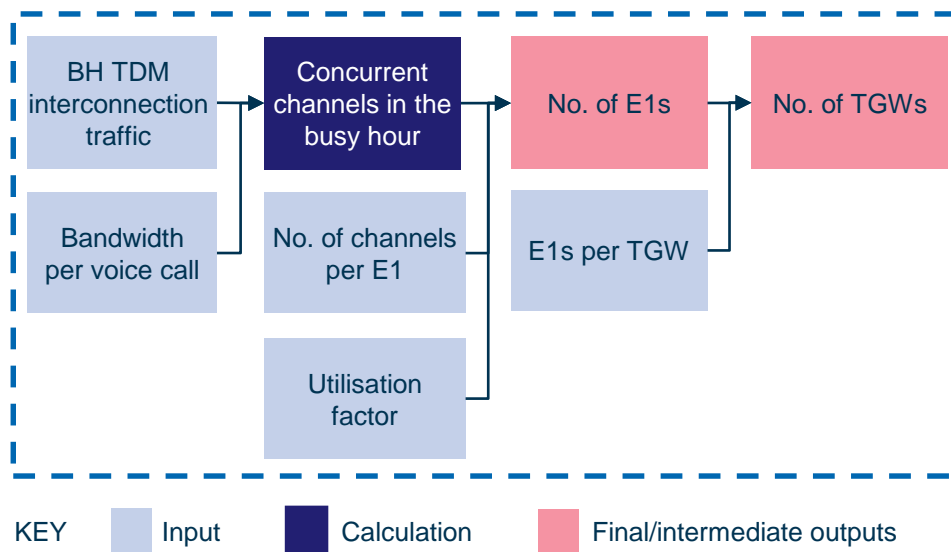

- The trunk gateway (TGW) translates the TDM-based voice traffic coming from other networks to IP for transit over the NGN core network
- The number of TGWs is driven by:
  - TDM interconnection traffic
  - number of channels per E1 and utilisation
  - E1 ports per gateway
- If all the interconnection traffic is TDM, no TGW will be deployed

### TGW's technical parameters

Parameter	Value	Source
Channels per E1	30	Analysys Mason, operators data
E1s per TGW	63	Analysys Mason, operators data
Ports utilisation factor	N/A*	Analysys Mason, operators data

## A number of other network elements are deployed at the core layer

Elements	Driver	Capacity measures	Minimum deployment	Source
Call server / soft-switch	BHCA	300 000 BHCA(*) Utilisation factor: N/A**	2 for the whole network	Analysys Mason, operator data
BRAS	Concurrent broadband subscribers	Share of concurrent subscribers in BH: N/A** Capacity: 48 000 connections Utilisation factor: N/A**	One per node	Analysys Mason, operator data
RADIUS server	Concurrent broadband subscribers	1 RADIUS per BRAS	One per node	Analysys Mason, operator data
DNS	Number of core nodes	2 DNS per node	2 DNS per node	Analysys Mason, operator data
Clock system	Number of core nodes	2 clock systems per node	2 clock systems per node	Analysys Mason estimate
VMS	Voice subscribers	Capacity: 5 000 000 subscribers Utilisation factor: N/A**	2	Analysys Mason estimate
VAS / application server (AS)	Voice subscribers	Capacity: 500 000 subscribers Utilisation factor: N/A**	2	Analysys Mason estimate
HSS	Voice subscribers	Capacity: 500 000 subscribers Utilisation factor: N/A**	1	Analysys Mason estimate
WBS	Daily call detail records (CDRs)	Capacity: 12 000 000 CDRs Utilisation factor: N/A**	2	Analysys Mason estimate
NMS	Number of core nodes	2 NMS per node	2 NMS per node	Analysys Mason estimate

**\*\* DATA REMOVED TO PROTECT CONFIDENTIAL OPERATOR INFORMATION**

## Dimensioning of the core rings

### High-level flow of calculations to dimension the core rings

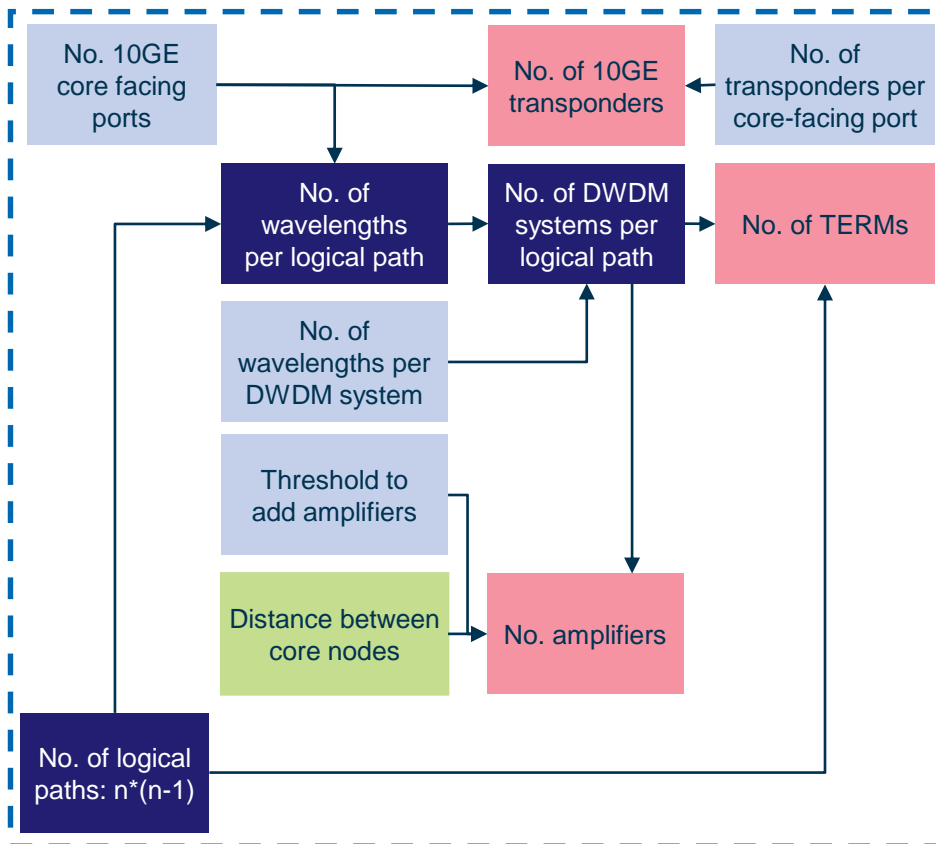

KEY  Input  'Offline' calculation  Calculation  Outputs

- Traffic at this layer is carried over DWDM rings
- The number of logical routes is based on the *fully meshed* formula  $n*(n-1)$ , where  $n$  is the number of core nodes
- **Methodology to estimate the number of transponders:**
  - transponders perform an OEO conversion
    - two transponders per uplink port are provisioned in order to transmit the signal to both sides of the ring
  - the model assumes that an optical amplifier needs to be deployed every 80km to maintain signal strength
- **Methodology to estimate the number of TERMS:**
  - TERMS are used to add and drop wavelengths into a WDM system
  - the number of TERMS is driven by both the number of DWDM systems per ring and the number of logical paths
    - a DWDM system can be used with up to 40 channels (wavelengths)
    - in the case where a new DWDM system is required, an additional fibre pair is used

## The calculated network assets feed into the service costing module

Structure of the fixed BU-LRIC model

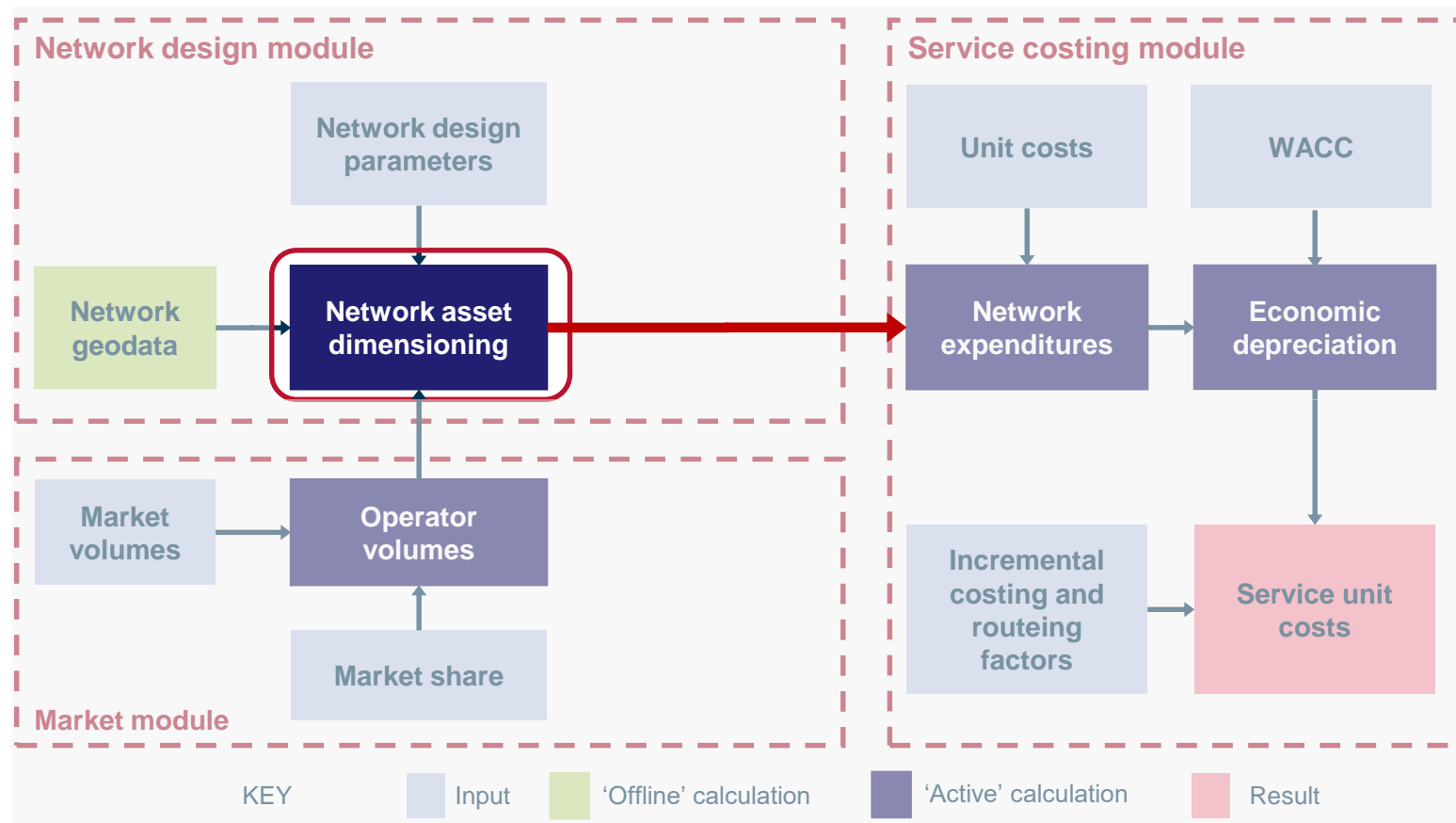

---

Introduction

Overview of the model

Market module

Network design module

**Service costing module**

Model results

Annexes

## The service costing module uses a combination of inputs from ANACOM, operators data and Analysys Mason estimates

### Main inputs used in the service costing module

Parameter	Source
Asset costs	Analysys Mason estimates, operator data
Cost trends	Analysys Mason estimates
Planning period	Analysys Mason estimates
Lifetimes	Analysys Mason estimates, operator data
Business overhead costs	Analysys Mason estimates, operator data

## Unit costs are based on data from recent fixed regulatory models and on the information provided by the operators [1/2]

- For each of the modelled network elements, we have derived the capital and opex unit costs :
  - unit costs are expressed in 2017 real-terms EUR
  - asset costs are assumed to already include installation and commissioning (I&C) and spares mark-up costs
- Unit costs are based on regulatory models recently developed by Analysys Mason and on information provided by the operators in response to our data requests:
  - data received from the operators is limited to specific categories
    - most of the Portuguese fixed operators did not provide unit equipment costs

### Unit costs used in the model

**GRAPH REMOVED TO PROTECT  
CONFIDENTIAL OPERATOR  
INFORMATION**

## Unit costs are based on data from recent fixed regulatory models and on the information provided by the operators [2/2]

---

Unit costs used in the model

Unit costs used in the model

**GRAPH REMOVED TO PROTECT  
CONFIDENTIAL OPERATOR  
INFORMATION**

**GRAPH REMOVED TO PROTECT  
CONFIDENTIAL OPERATOR  
INFORMATION**



## Equipment cost trends are estimated and applied over time

- Equipment prices have been on a declining trend in past years due to increased competition among vendors, economies of scale and as technologies mature:
  - the only exception is site acquisition, preparation & maintenance, and civil works, as the costs of these activities have risen due the increase in labour costs
- Opex cost trends are assumed to be zero in real terms
- Price trends are based on other regulatory models recently developed by Analysys Mason

### Cost trends used in the model (in real terms)

Category	Real-term price trend	Source
Port_cards	–8.0%	Analysys Mason
Chassis	–5.0%	Analysys Mason
Active_transmission_equipment	–5.0%	Analysys Mason
Passive_transmission_equipment	–1.0%	Analysys Mason
Service_platforms	–5.0%	Analysys Mason
BSS_OSS	–4.0%	Analysys Mason
Sites	2.0%	Analysys Mason
Trench_civil_works	2.0%	Analysys Mason
TV_Platform	–5.0%	Analysys Mason

## Network elements need to be purchased in advance, to allow provisioning, installation, configuration and testing before they are activated

- The network design algorithms compute the network elements that are required to support a given demand in each year (assessed at the year-average point):
  - ‘just-in-time’ activation
- However, network assets are typically purchased 1–12 months before they are activated, depending on lead-times and the size of the network
- The capex algorithm allows for all network elements to be purchased a few months before they are activated:
  - network elements need to be provisioned, installed, configured and tested before they are activated

### Capex planning period

Planning period (*)	Network elements	Source
1 year	Sites, ducts, fibre and submarine cables	Analysys Mason
9 months	DSLAMs, OLTs, switches, edge routers, SBCs, TGWs, core routers, call servers, OADMs, TERMS, SDH ADMs, DWDM amplifiers, WBS, NMS, clock systems, video on demand (VoD) and linear-TV platform	Analysys Mason
6 months	DNS, BRAS, RADIUS, HSS, VMS, IN platform	Analysys Mason
3 months	Port cards, transponders	Analysys Mason

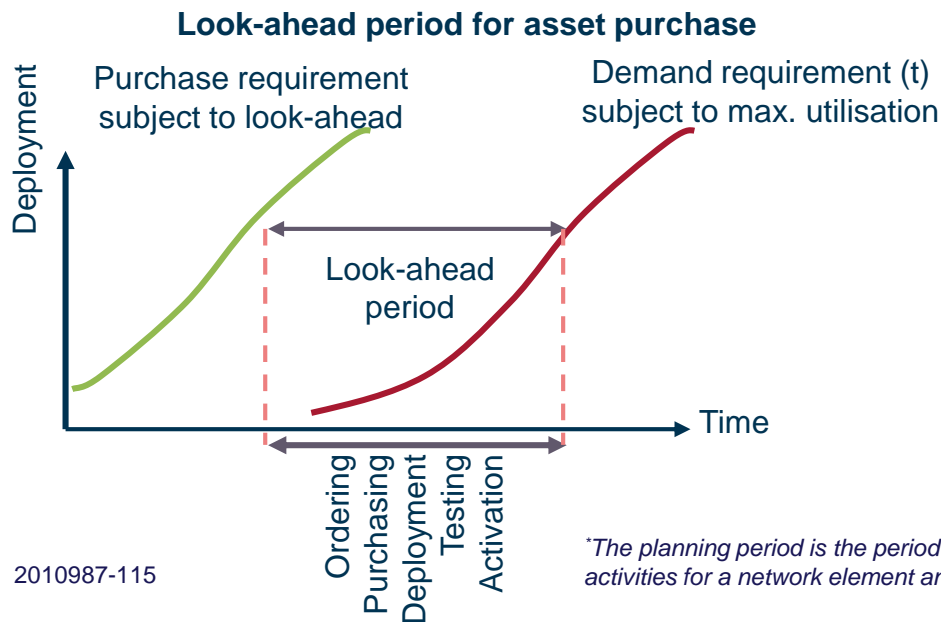

\*The planning period is the period of time that elapses between the first deployment expenditure activities for a network element and the time where the network element becomes operational

## The module calculates the amount of equipment that has reached the end of its lifetime and needs to be replaced over the modelled period

### Asset lifetimes assumed in the model

Lifetime (years)	Network elements	Source
40	Buried ducts, sites	Analysys Mason estimates, operator data
35	Aerial ducts	Analysys Mason estimates, operator data
20	Fibre cable	Analysys Mason estimates, operator data
15	Submarine fibre cables	Analysys Mason estimates, operator data
10	SDH ADM	Analysys Mason estimates, operator data
8	DSLAM, OLT, switch, edge router, SBC, TGW, core router, OADM, TERM, transponders, DWDM amplifiers, IN platform	Analysys Mason estimates, operator data
7	DNS, BRAS, RADIUS, HSS	Analysys Mason estimates, operator data
6	Ports cards, VMS, NMS, call server	Analysys Mason estimates, operator data
5	Clock system, VoD and linear-TV platform	Analysys Mason estimates, operator data
4	WBS	Analysys Mason estimates, operator data

## We have performed a high-level economic calibration comparing capex and opex calculated in the model with the data provided by operators

- We have performed an economic calibration by comparing the results of the model with the data provided by operators during the data request:
  - in order to do so, we have calculated the network costs incurred by the modelled operator in 2016 in nominal terms and using the straight-line depreciation
- Below, we show the methodology followed in order to calculate the costs incurred by the modelled operator

### High-level network cost calculation flow for calibration purposes

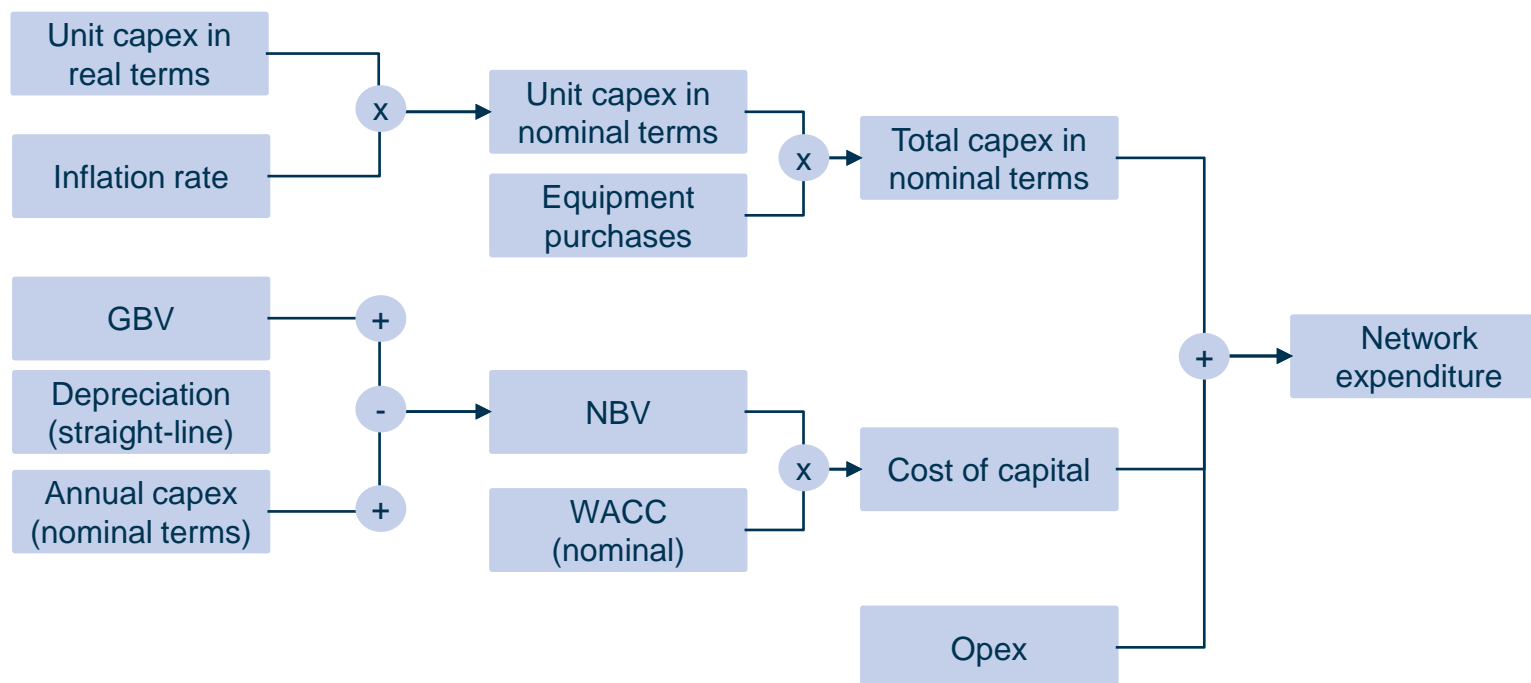

## Model calibration results

---

**CONTENT REMOVED TO PROTECT  
CONFIDENTIAL OPERATOR  
INFORMATION**

## Cumulative capex is modelled at EUR3.9 billion for the period 2008-2025

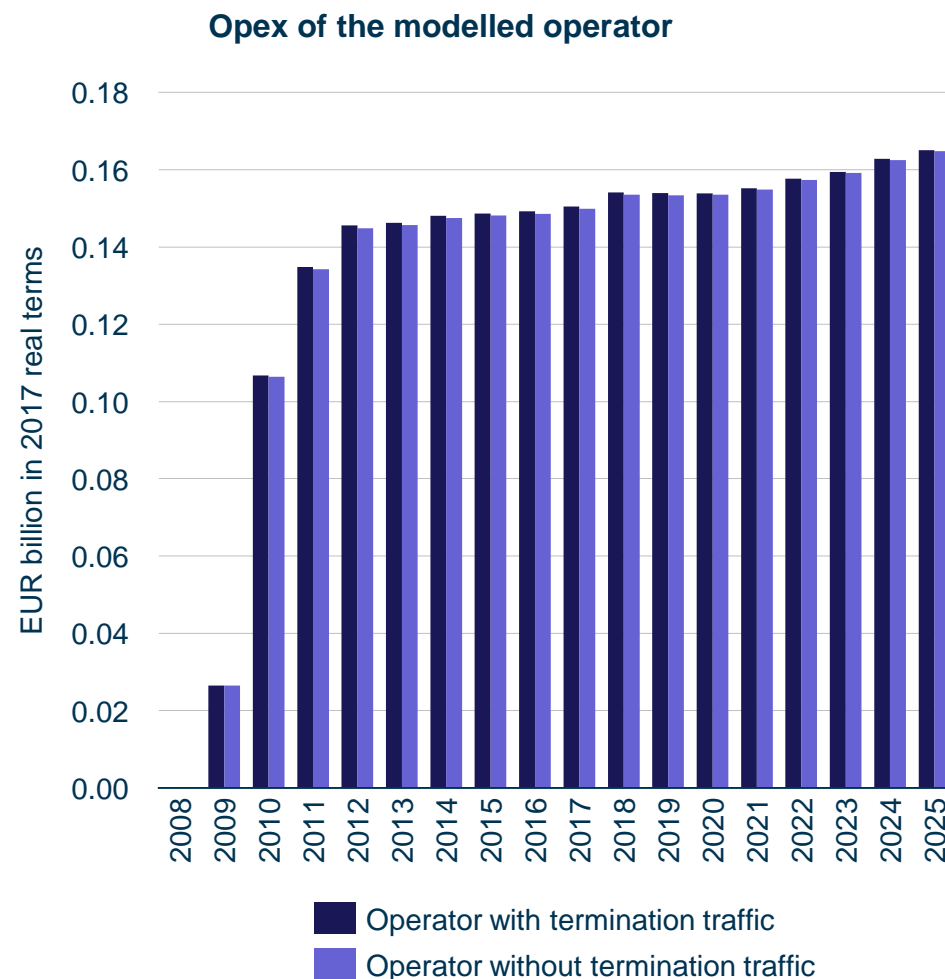
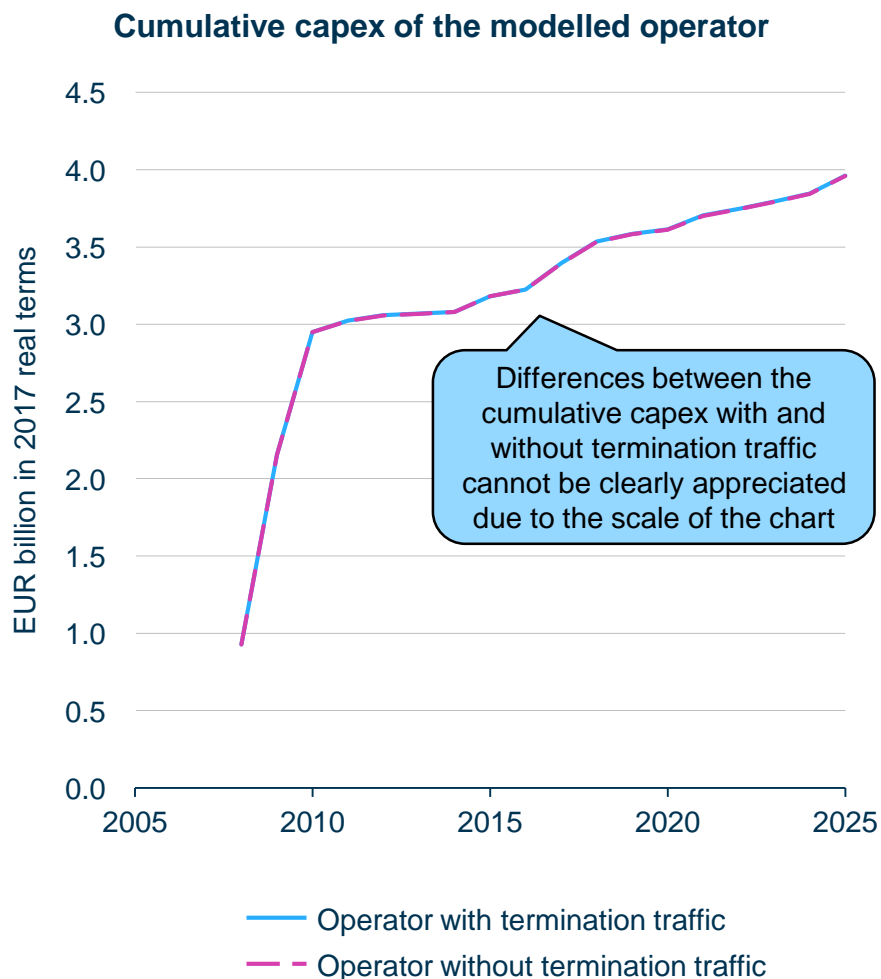

## Capex and opex are annualised using the *economic depreciation* method

- The algorithm implemented has the following characteristics:
  - it calculates the costs incurred over the lifetime of the network in present-value (PV) terms in line with the cost-oriented revenues generated by the business
  - it derives the cost-recovery profile for each asset along with the demand supported by that asset (its output profile)
  - the model includes a schedule of capex and opex for each network element (reflecting the price of modern equivalent assets (MEA) over time)
- Thus, the calculation of the costs recovered using the *economic depreciation* method is as follows:
 
$$\frac{PV(\text{expenditure})}{PV(\text{network element output})}$$
- The European Commission recommends that *economic depreciation* be used wherever feasible:
  - implementing the *economic depreciation* is consistent with the cost-recovery methodology used by ANACOM in its mobile BU-LRIC model

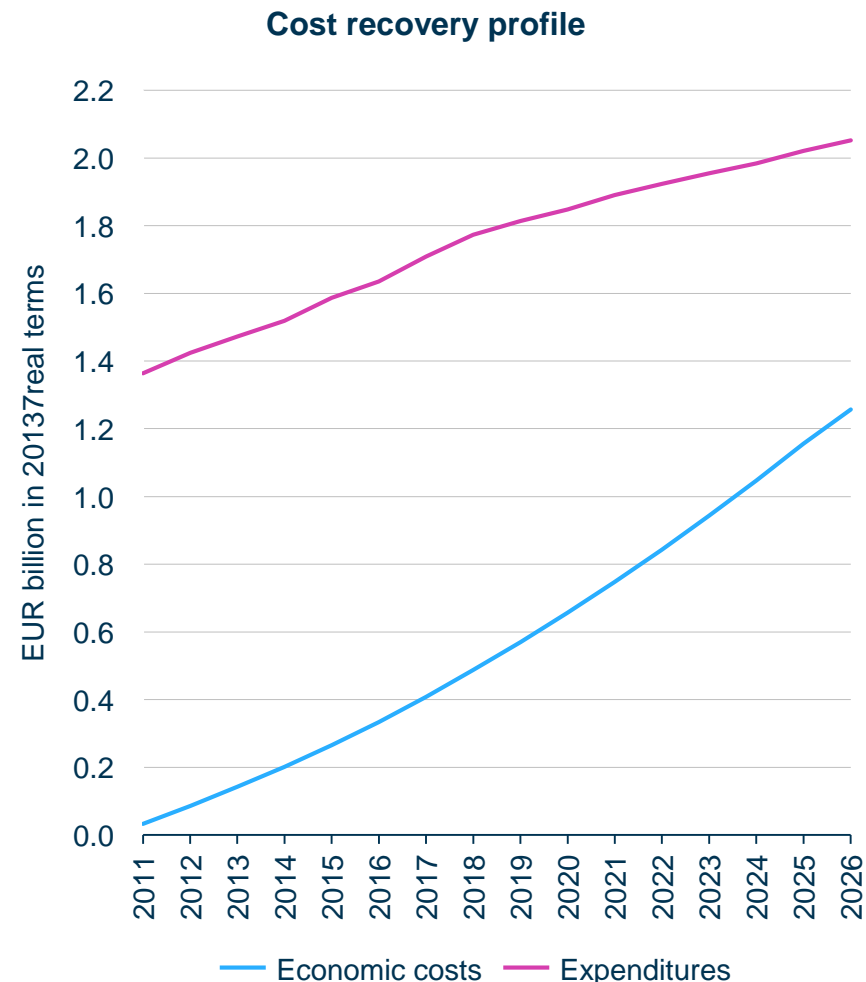

## In line with ANACOM's requirements, we have implemented two costing methods in the service costing module

- Two types of incremental and common costs have been implemented in the model:

- pure LRIC** defines the incremental cost of a service and
  - considers the increment to be all traffic generated by a single service
  - incremental costs are those that are avoided when not offering the wholesale termination service
- the pure BU-LRIC approach is consistent with the prevailing approach used for the costing of fixed voice termination in Europe, and in line with the methodology used in the mobile cost model built by ANACOM
- LRAIC+** is described as a large-increment approach
  - all services contributing to economies of scale are combined as a large increment
  - individual service costs are identified by sharing out the large (traffic) incremental cost according to average routeing factors
- LRAIC+ costs have been implemented in the model for information purposes

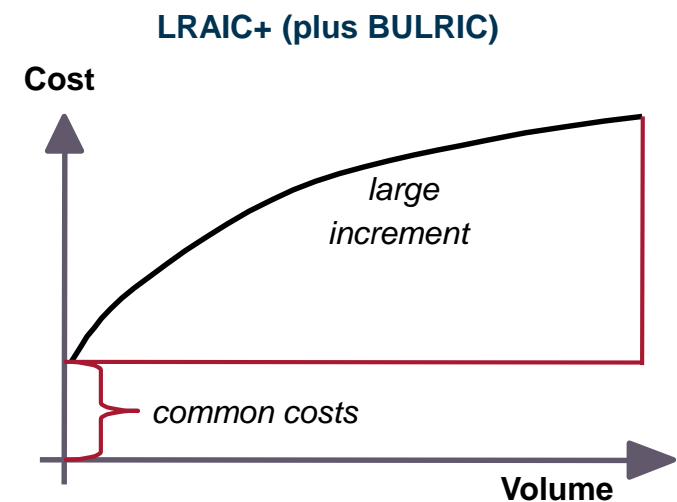
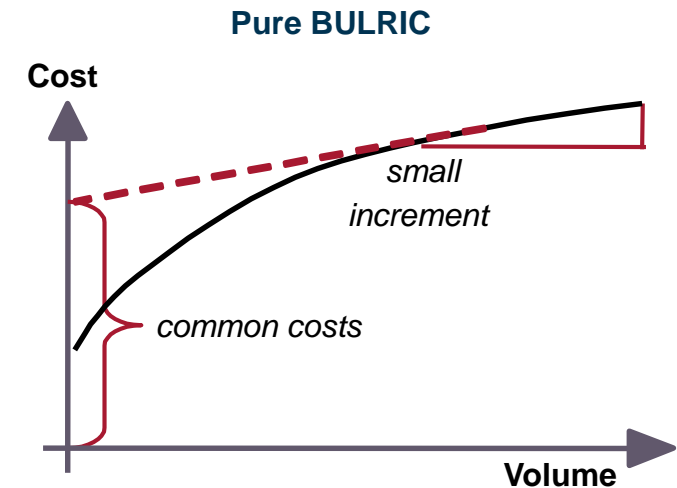



## The pure BU-LRIC approach only includes incremental costs

- The model uses a **pure BU-LRIC approach** based on the EC Recommendation:
  - only the cost ‘that is avoided when not offering voice termination’ is allocated to the wholesale termination service
  - non traffic-related costs, such as subscriber-related costs, are disregarded
  - network common costs and business overheads are not allocated to the wholesale termination service

### Pure BU-LRIC cost allocation

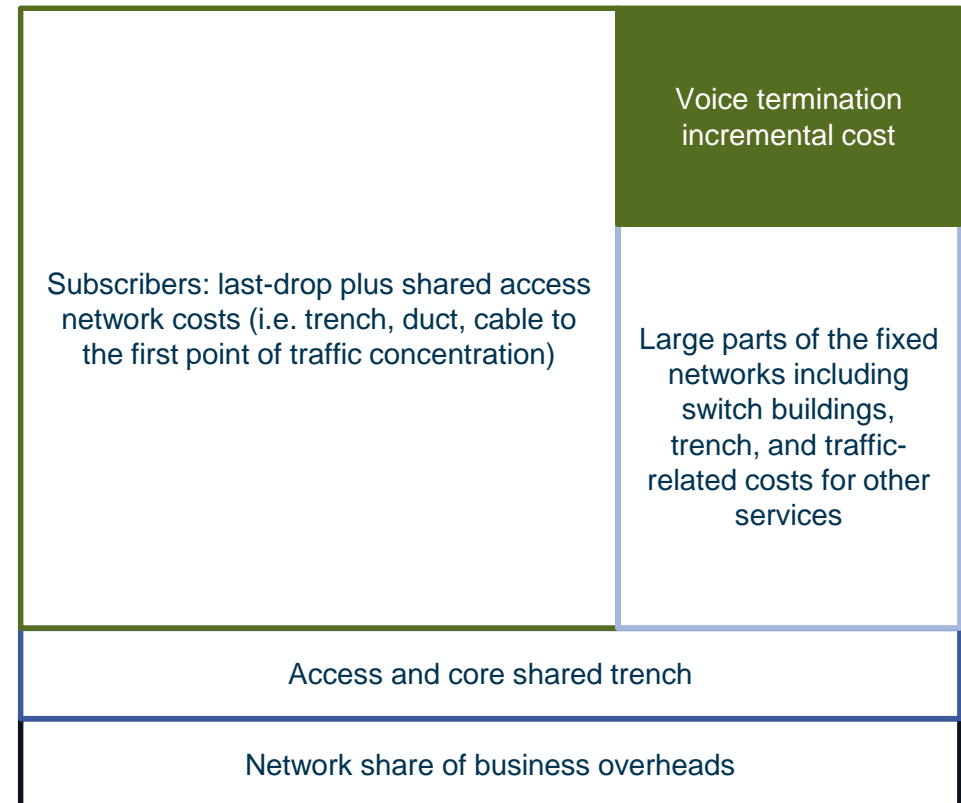

## The calculations needed for pure LRIC require the model to be run twice – this process is automated using a macro

- In order to run the pure LRIC calculations the button 'Calculate pure LRIC and LRAIC+' on the *Control* sheet of the file 1. Market.xlsx should be pressed
- The pure LRIC calculation is done in four stages:
  - runs the model and calculates the costs for all network elements, excluding the incremental cost of wholesale termination traffic from other networks
  - runs the model and calculates the costs for all network elements, including the incremental cost of wholesale termination traffic from other networks
  - calculates the difference in costs between the two scenarios, and annualises the difference using the economic depreciation method
  - divides the total annualised costs by the number of wholesale terminated minutes to derive the incremental cost per minute

### High-level flow to calculate pure LRIC costs

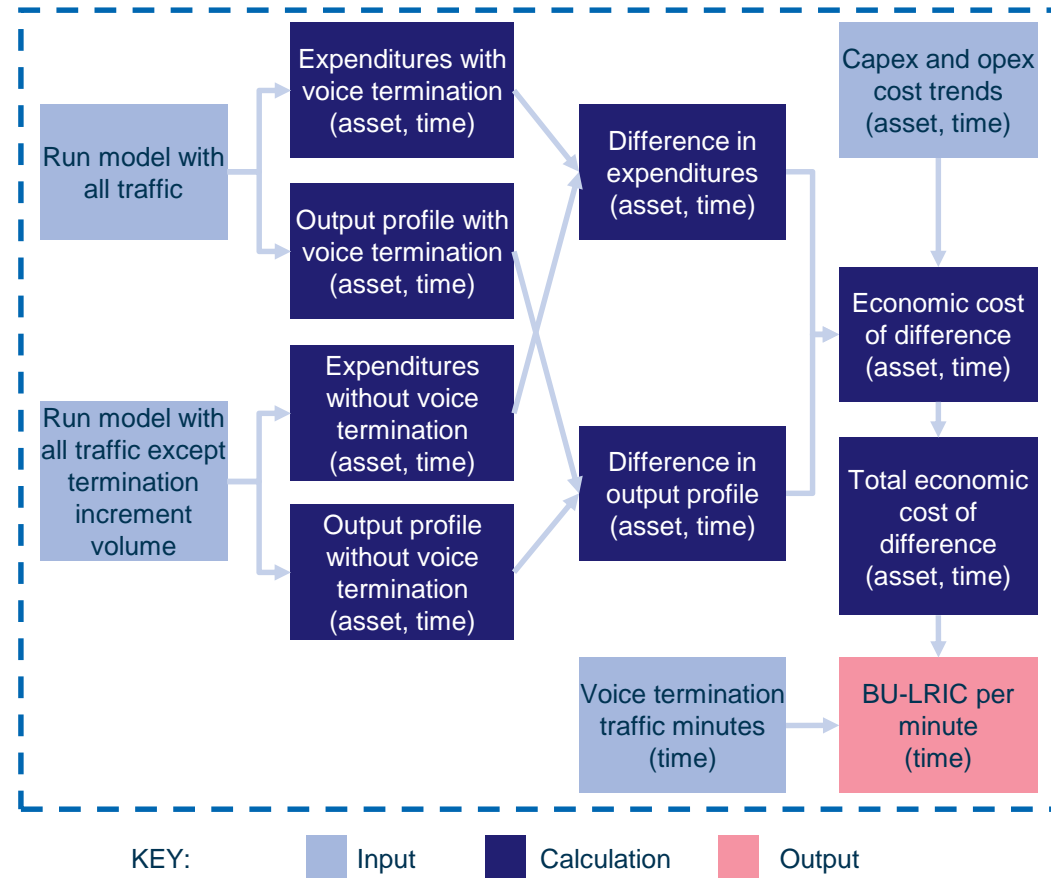

## In the LRAIC+ approach, the average incremental costs of traffic are defined in aggregate, and then allocated to the various traffic services

- Under a LRAIC+ approach the average incremental costs of traffic are defined in aggregate, then allocated to the various traffic services using routing factors
- A large traffic increment implies that costs common to multiple traffic services are included in the average incremental cost of traffic
- Common costs are included in the LRAIC+ approach using and equi-proportional cost-based mark-up (EPMU):
  - the costs associated with business overhead activities are considered to be common to both traffic and subscribers (the fixed access network), and are assumed to represent 5% of total costs
    - this is in line with other recent fixed core models built by other regulators in Europe and with the information provided by the fixed operators in Portugal
- In order to run the model to calculate LRAIC+, press either the button 'Calculate pure LRIC and LRAIC+' or 'Calculate LRAIC+' on the *Control* sheet within the file 1. Market.xlsx

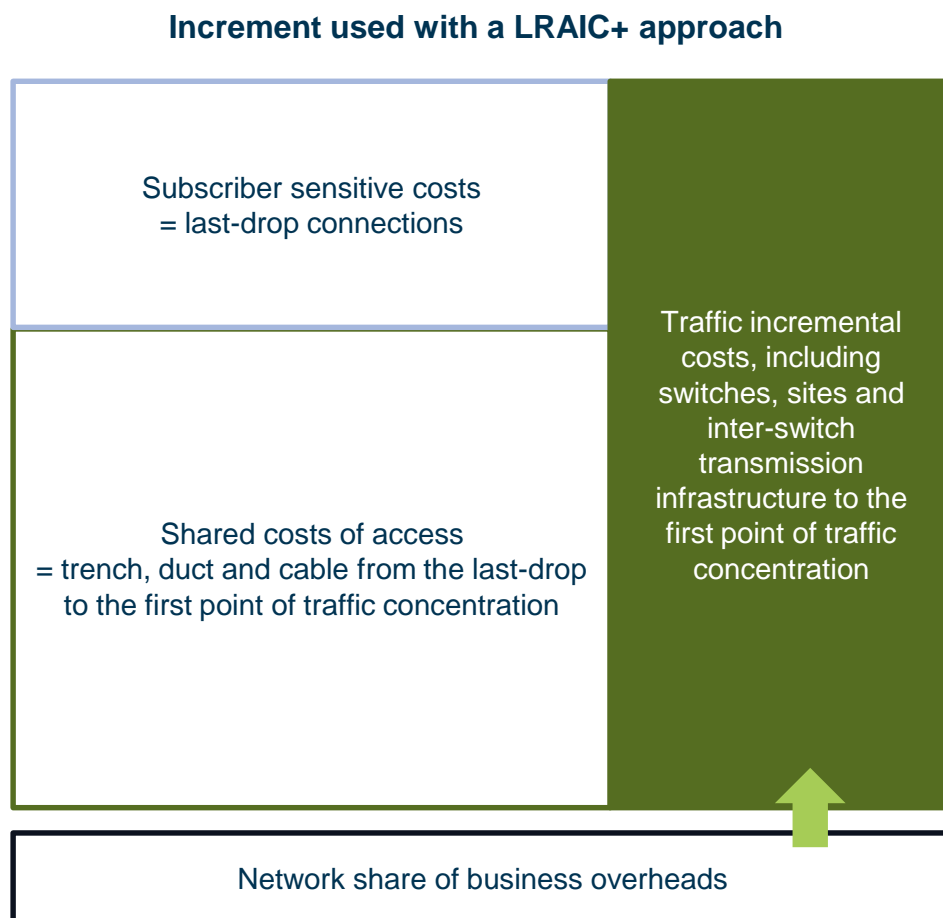

---

Introduction

Overview of the model

Market module

Network design module

Service costing module

**Model results**

Annexes

## The regulatory fees paid by the operators are included in the termination cost calculated by the model

### Regulation

- The regulatory annual fees paid by the Portuguese operators are calculated according to their size in terms of annual revenues
  - for this purpose, they are split in three tiers: Tier 0 operators (with revenues below EUR250k) do not pay any fee; Tier 1 operators (revenues between EUR250k and EUR1,500k) pay a fixed fee of EUR2,500; Tier 2 operators (with revenues higher than EUR1,500k) pay a variable regulatory fee  $T_2$ , as a percentage of their revenues, i.e.  $T_2 = t_2 \times R_2$ , where  $t_2$  is the fee rate (expressed as a percentage of revenue) and  $R_2$  is the relevant revenue, which excludes VAT, selling of terminals (equipment), transactions between entities of the same group and revenues from the universal service
- The percentage of revenue  $t_2$  is calculated as  $t_2 = \frac{C - (t_1 \times n_1)}{\sum R_2}$ , where
  - $C$  represents the cost to execute the regulatory activity
  - $t_1 \times n_1$  represents the fees paid by Tier 1 operators, being  $t_1$  the fixed EUR2,500 fee and  $n_1$  the number of Tier 1 operators
  - $\sum R_2$  is the sum of the relevant revenues of all the Tier 2 operators in the previous year

### Model

- To include the above in the fixed BU-LRIC model, we made the following assumptions:
  - in light of the scale of the modelled operator, it is reasonable to model it as a Tier 2 one
  - the regulated fixed termination rate applied is a cost-oriented value, and then the (unit) revenue from termination equals the (unit) termination cost calculated by the model
- The regulatory fees paid by the operator attributable to the fixed termination service can be calculated as  $T_2 = t_2 \times \text{Termination cost}$ , and consequently the termination cost including the regulatory fees is calculated as  $\text{Termination cost}_{with\ regulatory\ fees} = \text{Termination cost} \times (1 + t_2)$  (this applies to both pure LRIC and LRAIC+)
- In light of the actual values, a long-term value of 0.7% for  $t_2$  appears reasonable

## Model results

---

**CONTENT REMOVED TO PROTECT  
CONFIDENTIAL OPERATOR  
INFORMATION**

## The model calculates a stable number of DSLAMs and OLTs

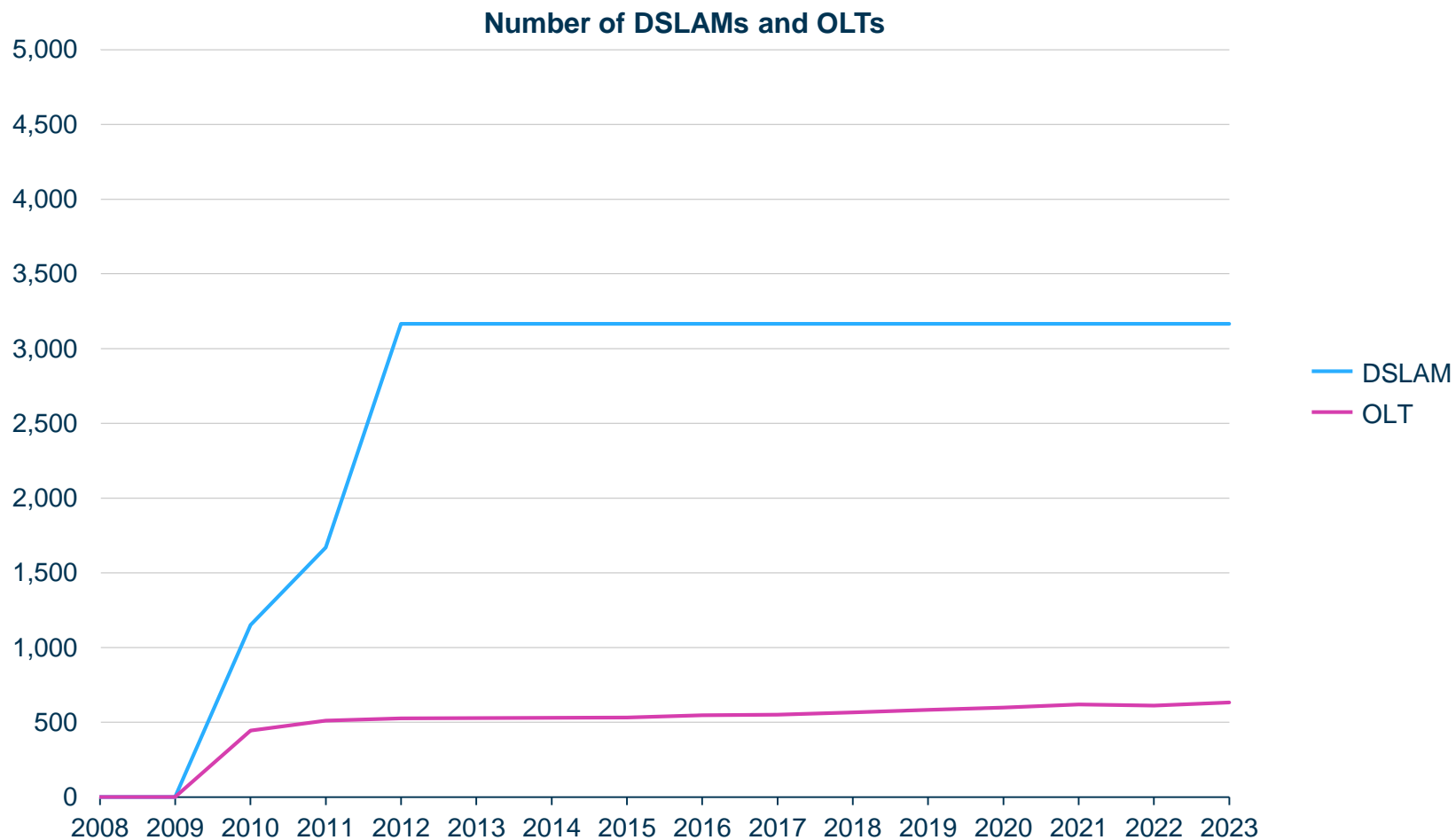

## The number of aggregation switches and SBCs is expected to remain constant over the modelled period

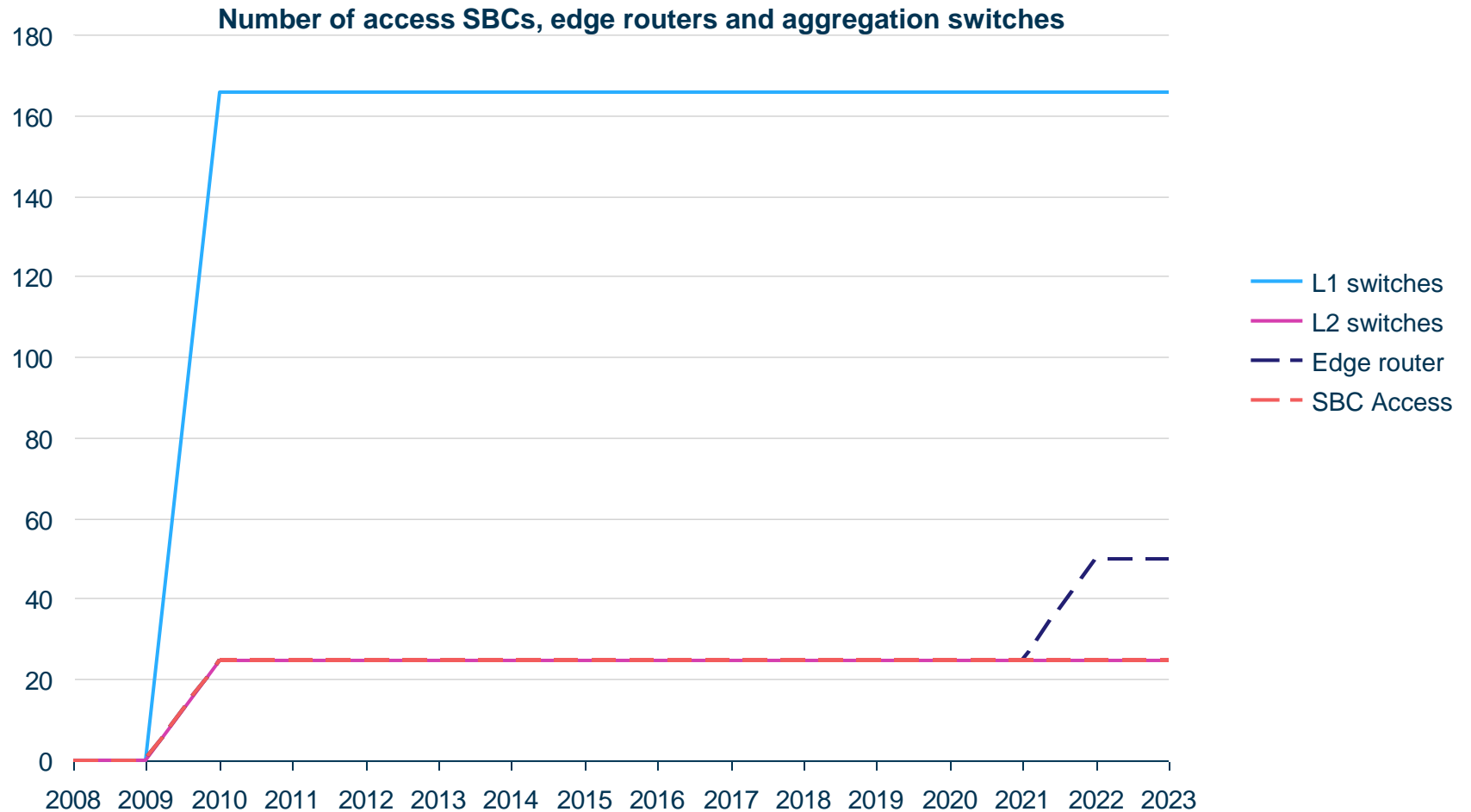



## The number of core routers and core switches is forecast to rise due to the increase in data traffic

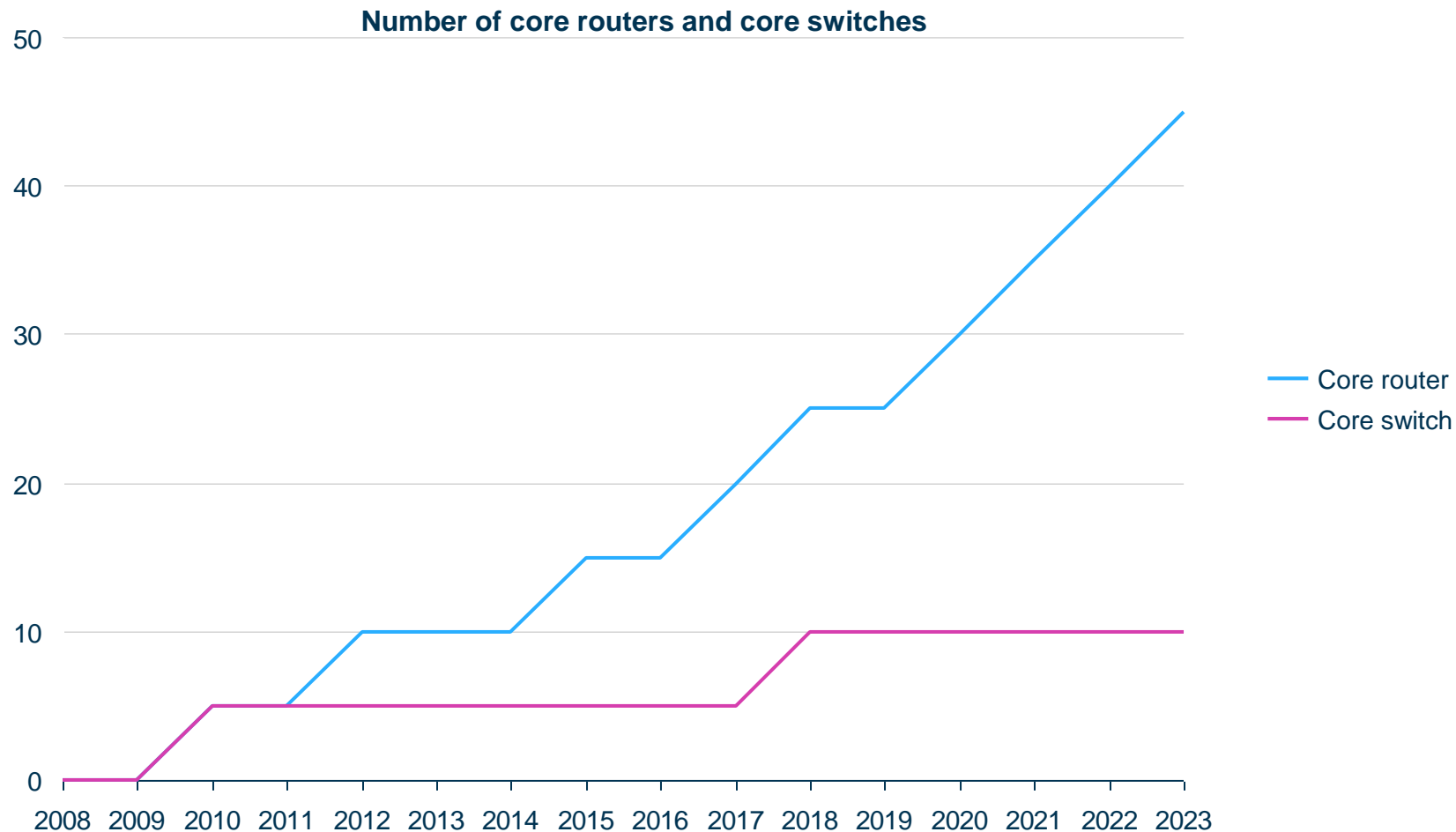

## The increase in data traffic will also drive the growth in the number of BRAS and RADIUS servers

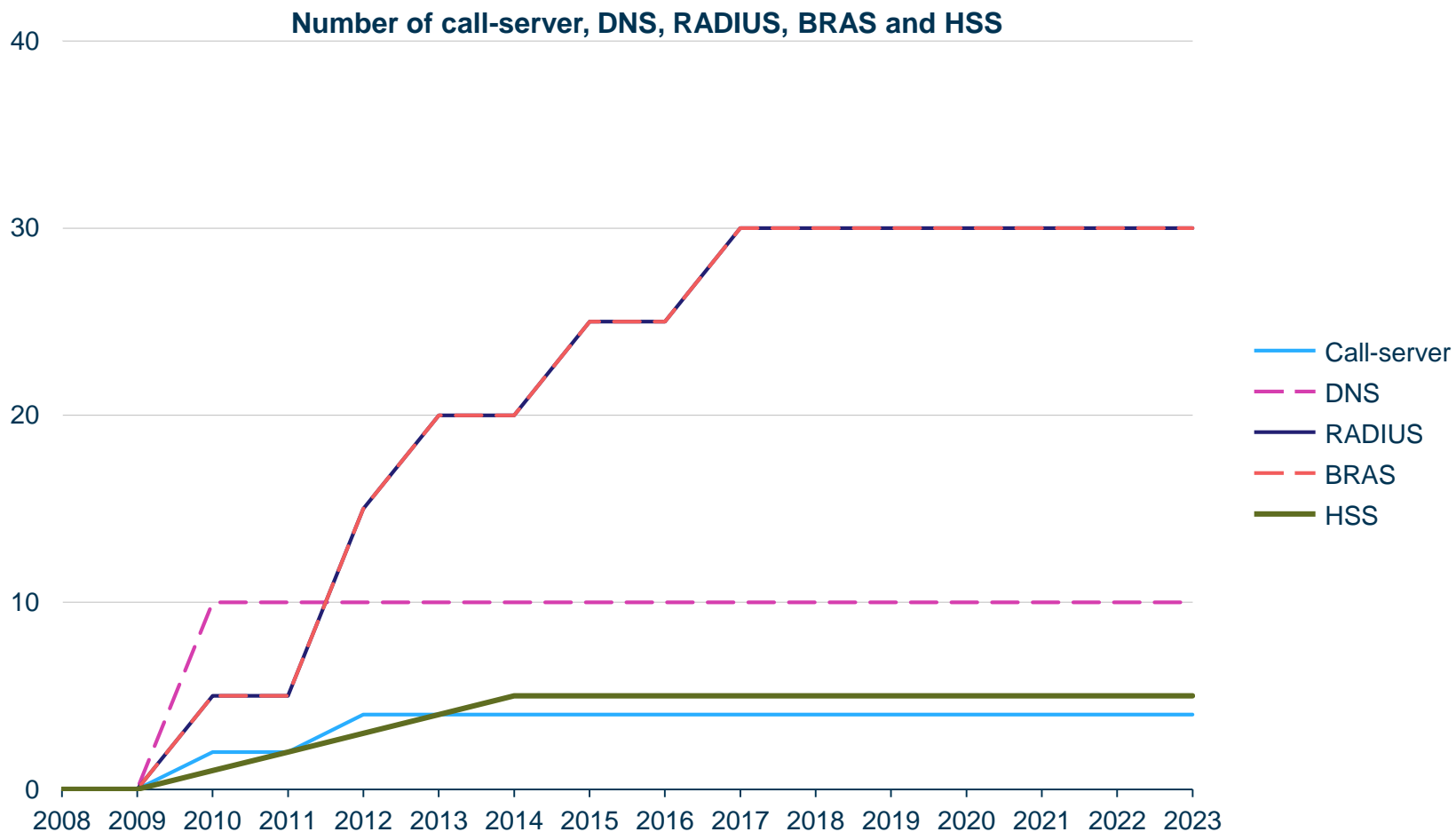

# Annexes

---

## Instructions on how to run the model

Description of the model sheets

List of model inputs

Glossary of terms

## Instructions on how to run the model

---

- To run the model, the following steps should be followed:
  - make sure that all three Excel files of the costing model (*1.Market.xlsx*, *2.Network.xlsx* and *3.Service costing.xlsx*) are saved in the same directory to preserve the inter-workbook links
  - open the three workbooks: when given the choice whether to enable macros, click ‘Enable Macros’
  - check that the three files are all linked together (using *Data -> Edit Links*)
  - set the other necessary parameters in the *Control* sheet of the file *1.Market.xlsx*, as described in the following slides
- To run the model according to the various costing approaches, the macro must be used:
  - click the ‘Calculate pure LRIC and LRAIC+’ button to calculate LRAIC+ unit costs for all services, and pure LRIC unit costs for wholesale termination
  - click the ‘Calculate LRAIC+’ button to calculate LRAIC+ unit costs for all services
  - click the ‘Run model without termination’ button to calculate LRAIC+ unit costs for all services, excluding the wholesale termination traffic

---

Instructions on how to run the model

**Description of the model sheets**

List of model inputs

Glossary of terms

## Description of the sheets comprising the *market module*

Sheet name	Description
<i>Control</i>	Control panel where the model can be run and the main options can be defined
<i>Demand</i>	Calculates the past, present and future state of the Portuguese market within the period considered in our model, in terms of traffic, penetration and subscribers
<i>Operator</i>	Derives the demand for the modelled operator by multiplying the market share by the total traffic per service
<i>Output</i>	Summarises the outputs that feed into the other modules
<i>Geotypes</i>	Calculates the past, present and future distribution of subscribers per service and geotype
<i>Curves</i>	Models different migration curves for the operator (e.g. s-curve, exponential, negative exponential)
<i>Lists</i>	Defines named ranges of commonly used lists in the model

## Description of the sheets comprising the *network design module*

Excel sheet	Description
<i>Import from market</i>	Imports the main model parameters, network subscriber forecasts, service demand forecasts from the market model
<i>Demand subs calculation</i>	Calculates the traffic demand in the busy hour of the modelled operator and allocates the traffic of the market services to their network service
<i>Physical network</i>	Imports the kilometres of fibre and ducts for each of the network layers from an offline geo-analysis
<i>Network design inputs</i>	Defines input network load parameters such as traffic profiles, utilisation factors, technical parameters (e.g. number of ports per card, number of cards per shelf, etc.)
<i>Network design</i>	Calculates the network requirements for each part of the fixed network according to detailed network design algorithms, demand drivers and network design inputs
<i>Full_network</i>	Collates the number of network elements required in each year according to the demand drivers and network design rules
<i>Asset_inputs</i>	Defines the planning period, retirement delay and asset lifetimes
<i>Network_common</i>	Defines the proportion of common costs allocated to each type of network element
<i>Network_deployment</i>	Calculates the number of network elements purchased in each year according to the planning period and network element lifetime
<i>Routing_factors</i>	Collates the routing factor load of each service per network element
<i>Network_element_output</i>	Calculates the recovery profile and the traffic loading on each type of network element
<i>Lists</i>	Defines named ranges of commonly used lists in the model

## Description of the sheets comprising the *service costing module*

Excel sheet	Description
<i>Lists</i>	Defines named ranges of commonly used lists in the model
<i>Asset_inputs</i>	Defines the unit capex and unit opex for each network element
<i>Network_element_inputs</i>	Imports the output of the network design module, i.e. number of network elements, equipment purchases, traffic loading on each network element, etc.
<i>Cost_trends</i>	Inputs the capex and opex cost trends for various asset groups and determines the capex and opex cost trends for each network element
<i>Unit_capex</i>	Calculates the capex per network element according to the unit capex costs and capex trends
<i>Total_capex</i>	Calculates total capex by multiplying the unit capex with the number of network elements purchased
<i>Unit_opex</i>	Calculates the capex per network element according to the unit opex costs and opex trends, including an allowance for working capital
<i>Total_opex</i>	Calculates total opex by multiplying unit opex with number of network elements operated each year
<i>Discount factors</i>	Calculates the real discount and inflation rates
<i>Service demand matrix</i>	Converts retail service demand to network service demand, e.g. by converting retail kbit/s into an equivalent volume of minutes
<i>ED</i>	Calculates annualised costs over time, in total and per unit output, according to PV of expenditures and PV of (production output x price index)
<i>plusLRAIC</i>	Calculates marked-up unit average incremental costs of all services over time
<i>pureLRIC</i>	Calculates pure incremental costs: avoided annualised costs of wholesale termination
<i>Results fixed</i>	Summarises the LRAIC+ and pure LRIC results for the fixed LRIC model



## Formatting and naming conventions used in the model

- A consistent cell format has been used throughout all sheets of the model. This is to increase the transparency of the model, as well as making it easier to understand and modify
- A number of standardised cell formats are used to distinguish inputs, assumptions, calculations and links. The most important conventions are shown to the right

### Formatting conventions used in the model

Parameter

Data

Estimate

Input calculation

Link (same workbook)

Link (another workbook)

*Named range*

---

Instructions on how to run the model

Description of the model sheets

**List of model inputs**

Glossary of terms

## The main model inputs are sourced from ANACOM, operator data and Analysys Mason estimates

---

- We have used a range of data sources to build the cost model. The main inputs have been source primarily from:
  - ANACOM’s statistical data on the Portuguese market
  - operator data whenever available, which has been used either as an average, or as an indicator from which Analysys Mason estimates have been derived
  - Analysys Mason estimates, based on our extensive cost modelling experience across different geographies, and our knowledge and research of the Portuguese market
- Other inputs have been sourced from third-party data, including:
  - Analysys Mason Research, Euromonitor International, European Commission, among others
- In the following slides we provide a brief description of the main model inputs and their location in the Excel workbook:
  - some of the inputs are grouped together; for instance, the input ‘average call duration’ includes the average call duration for on-net calls, outgoing and incoming calls, international calls, etc.
- For ease of reference, we have used the name of the input in the model whenever possible

## List of model inputs: 1. Market.xlsx [1/2]

Model sheet	Model inputs	Source
Control	<ul style="list-style-type: none"> <li>▪ WACC</li> <li>▪ Market share at launch</li> <li>▪ Market share in target year</li> <li>▪ Years of operations</li> </ul>	<ul style="list-style-type: none"> <li>▪ ANACOM de-inflated with Euromonitor International data</li> <li>▪ ANACOM</li> <li>▪ ANACOM</li> <li>▪ ANACOM</li> </ul>
Demand	<ul style="list-style-type: none"> <li>▪ Population</li> <li>▪ Households</li> <li>▪ Fixed voice connections</li> <li>▪ Mobile voice connections</li> <li>▪ Fixed broadband connections</li> <li>▪ High-speed broadband connections</li> <li>▪ Bitstream subscribers</li> <li>▪ Homes passed by NGA technologies</li> <li>▪ Leased lines</li> <li>▪ Pay TV connections</li> <li>▪ VoD and OTT subscribers</li> <li>▪ Voice traffic per fixed subscriber</li> <li>▪ Voice traffic per mobile subscribers</li> <li>▪ Data traffic per mobile subscriber</li> <li>▪ International incoming traffic</li> <li>▪ Wholesale outgoing traffic</li> <li>▪ Wholesale transit traffic</li> <li>▪ Nodes by geotype</li> <li>▪ Local exchanges with OLTs</li> <li>▪ Average call duration</li> </ul>	<ul style="list-style-type: none"> <li>▪ Portuguese MTR 2017 model</li> <li>▪ Analysys Mason Research</li> <li>▪ ANACOM, Analysys Mason Research</li> <li>▪ Portuguese 2017 MTR model</li> <li>▪ ANACOM, Analysys Mason Research</li> <li>▪ ANACOM</li> <li>▪ European Commission</li> <li>▪ ANACOM</li> <li>▪ ANACOM</li> <li>▪ ANACOM, Analysys Mason Research</li> <li>▪ ANACOM, Analysys Mason Research</li> <li>▪ ANACOM</li> <li>▪ Portuguese 2017 MTR model</li> <li>▪ Portuguese 2017 MTR model</li> <li>▪ ANACOM</li> <li>▪ ANACOM</li> <li>▪ ANACOM</li> <li>▪ ANACOM, Analysys Mason estimates</li> <li>▪ ANACOM, Analysys Mason estimates</li> <li>▪ ANACOM</li> </ul>

## List of model inputs: 1. Market.xlsx [2/2]

Model sheet	Model inputs	Source
Operator	<ul style="list-style-type: none"> <li>New entrant in the geotype 3</li> </ul>	<ul style="list-style-type: none"> <li>ANACOM</li> </ul>
Geotypes	<ul style="list-style-type: none"> <li>Number of subscribers per geotype</li> </ul>	<ul style="list-style-type: none"> <li>ANACOM, operators data</li> </ul>
Lists	<ul style="list-style-type: none"> <li>Voice bitrate</li> <li>Number of busy days per year</li> <li>Proportion of weekly traffic during busy days</li> <li>Proportion of daily traffic during the busy hour</li> </ul>	<ul style="list-style-type: none"> <li>Analysys Mason, operator data</li> <li>Analysys Mason, operator data</li> <li>Analysys Mason, operator data</li> <li>Analysys Mason, operator data</li> </ul>



## List of model inputs: 2. Network.xlsx [2/2]

Model sheet	Model inputs	Source
Network design inputs	<ul style="list-style-type: none"> <li>▪ TGW characteristics</li> <li>▪ SBCs for interconnection characteristics</li> <li>▪ Core ring characteristics</li> <li>▪ Call-server characteristics</li> <li>▪ BRAS characteristics</li> <li>▪ RADIUS characteristics</li> <li>▪ DNS characteristics</li> <li>▪ Clock system characteristics</li> <li>▪ VMS characteristics</li> <li>▪ AS characteristics</li> <li>▪ HSS characteristics</li> <li>▪ WBS characteristics</li> <li>▪ NMS characteristics</li> </ul>	<ul style="list-style-type: none"> <li>▪ Analysys Mason estimates, operator data</li> <li>▪ Analysys Mason estimates, operator data</li> <li>▪ Analysys Mason estimates, operator data</li> <li>▪ Analysys Mason estimates, operator data</li> <li>▪ Analysys Mason estimates, operator data</li> <li>▪ Analysys Mason estimates, operator data</li> <li>▪ Analysys Mason estimates, operator data</li> <li>▪ Analysys Mason estimates</li> <li>▪ Analysys Mason estimates</li> <li>▪ Analysys Mason estimates</li> <li>▪ Analysys Mason estimates</li> <li>▪ Analysys Mason estimates</li> <li>▪ Analysys Mason estimates</li> </ul>
Asset_inputs	<ul style="list-style-type: none"> <li>▪ Retirement delay</li> <li>▪ Asset lifetime</li> <li>▪ Planning period</li> </ul>	<ul style="list-style-type: none"> <li>▪ Analysys Mason estimates</li> <li>▪ Analysys Mason estimates, operator data</li> <li>▪ Analysys Mason estimates</li> </ul>
Lists	<ul style="list-style-type: none"> <li>▪ Leased line contention ratio</li> <li>▪ Number of FTE for the wholesale interconnection team</li> </ul>	<ul style="list-style-type: none"> <li>▪ Analysys Mason estimates, operator data</li> <li>▪ Analysys Mason estimates</li> </ul>

## List of model inputs: 3. *Service costing.xlsx*

Model sheet	Model inputs	Source
Asset_inputs	<ul style="list-style-type: none"> <li>▪ Capex per unit</li> <li>▪ Opex per unit</li> </ul>	<ul style="list-style-type: none"> <li>▪ Analysys Mason estimates, operator data</li> <li>▪ Analysys Mason estimates, operator data</li> </ul>
Cost trends	<ul style="list-style-type: none"> <li>▪ Equipment capital expenditure trends</li> <li>▪ Equipment operating expenditure trends</li> </ul>	<ul style="list-style-type: none"> <li>▪ Analysys Mason estimates</li> <li>▪ Analysys Mason estimates</li> </ul>
Discount factors	<ul style="list-style-type: none"> <li>▪ Inflation</li> </ul>	<ul style="list-style-type: none"> <li>▪ Euromonitor International</li> </ul>
plusLRAIC	<ul style="list-style-type: none"> <li>▪ Business overhead costs</li> </ul>	<ul style="list-style-type: none"> <li>▪ Analysys Mason estimates, operator data</li> </ul>



---

Instructions on how to run the model

Description of the model sheets

List of model inputs

**Glossary of terms**

- **ADM** – Add-drop multiplexer
- **ANACOM** – Autoridade Nacional de Comunicações
- **AS** – Application server
- **BAP** – Bandwidth allocation protocol
- **BHCA** – Busy-hour call attempt
- **BRAS** – Broadband remote access server
- **BU-LRIC** – Bottom-up long-run incremental cost
- **CAGR** – Compound annual growth rate
- **CDR** – Call detail record
- **CS** – Call server
- **CWDM** – Coarse wavelength division multiplexing
- **DNS** – Domain name server
- **DSLAM** – Digital subscriber line access multiplexer
- **DTH** – Direct to home
- **DWDM** – Dense wavelength division multiplexing
- **EC** – European Commission
- **EPMU** – Equi-proportionate mark-up
- **FTE** – Full-time equivalent
- **FTTH** – Fibre to the home
- **GPON** – Gigabit passive optical network
- **HSS** – Home subscriber server
- **I&C** – Installation and commissioning
- **IP** – Internet protocol
- **IPTV** – Internet protocol television
- **LRAIC** – Long-run average incremental cost
- **MEA** – Modern equivalent asset
- **MPLS** – Multi-protocol label switching
- **NGA** – Next-generation access
- **NGN** – Next-generation network
- **NMS** – Network management system
- **OADM** – Optical add-drop multiplexer
- **OEO** – Optical electrical optical
- **OLT** – Optical line terminal
- **OTT** – Over the top
- **PTP** – Point to point
- **PV** – Present value
- **RADIUS** – Remote authentication dial-in user service
- **SBC** – Session border controller
- **SDH** – Synchronous digital hierarchy
- **TDM** – Time division multiplexing
- **TERM** – Terminal multiplexor
- **TWG** – Trunking gateway
- **VAS** – Value-added service
- **VMS** – Voice main server
- **VoD** – Video on demand
- **VoIP** – Voice over Internet protocol
- **VPN** – Virtual private network
- **WACC** – Weighted average cost of capital
- **WBS** – Wholesale billing system
- **WDM** – Wavelength division multiplexing

## Contact details

---

### Gilles Monniaux

Principal

[gilles.monniaux@analysismason.com](mailto:gilles.monniaux@analysismason.com)

### Pedro Braz Caria

Manager

[pedro.braz.caria@analysismason.com](mailto:pedro.braz.caria@analysismason.com)

### Andres Flores

Associate Consultant

[andres.flores@analysismason.com](mailto:andres.flores@analysismason.com)

#### Boston

Tel: +1 202 331 3080

Fax: +1 202 331 3083

[boston@analysismason.com](mailto:boston@analysismason.com)

#### Cambridge

Tel: +44 (0)1223 460600

Fax: +44 (0)1223 460866

[cambridge@analysismason.com](mailto:cambridge@analysismason.com)

#### Dubai

Tel: +971 (0)4 446 7473

Fax: +971 (0)4 446 9827

[dubai@analysismason.com](mailto:dubai@analysismason.com)

#### Dublin

Tel: +353 (0)1 602 4755

Fax: +353 (0)1 602 4777

[dublin@analysismason.com](mailto:dublin@analysismason.com)

#### Johannesburg

Tel: +27 (0)10 596 8000

Fax: +27 (0)86 504 4764

[johannesburg@analysismason.com](mailto:johannesburg@analysismason.com)

#### London

Tel: +44 (0)20 7395 9000

Fax: +44 (0)20 7395 9001

[london@analysismason.com](mailto:london@analysismason.com)

#### Madrid

Tel: +34 91 399 5016

Fax: +34 91 451 8071

[madrid@analysismason.com](mailto:madrid@analysismason.com)

#### Manchester

Tel: +44 (0)161 877 7808

Fax: +44 (0)161 877 7810

[manchester@analysismason.com](mailto:manchester@analysismason.com)

#### Milan

Tel: +39 02 76 31 88 34

Fax: +39 02 36 50 45 50

[milan@analysismason.com](mailto:milan@analysismason.com)

#### New Delhi

Tel: +91 124 4501860

[newdelhi@analysismason.com](mailto:newdelhi@analysismason.com)

#### Paris

Tel: +33 (0)1 72 71 96 96

Fax: +33 (0)1 72 71 96 97

[paris@analysismason.com](mailto:paris@analysismason.com)

#### Singapore

Tel: +65 6493 6038

Fax: +65 6720 6038

[singapore@analysismason.com](mailto:singapore@analysismason.com)